

THINK PARTS THINK TORNOS

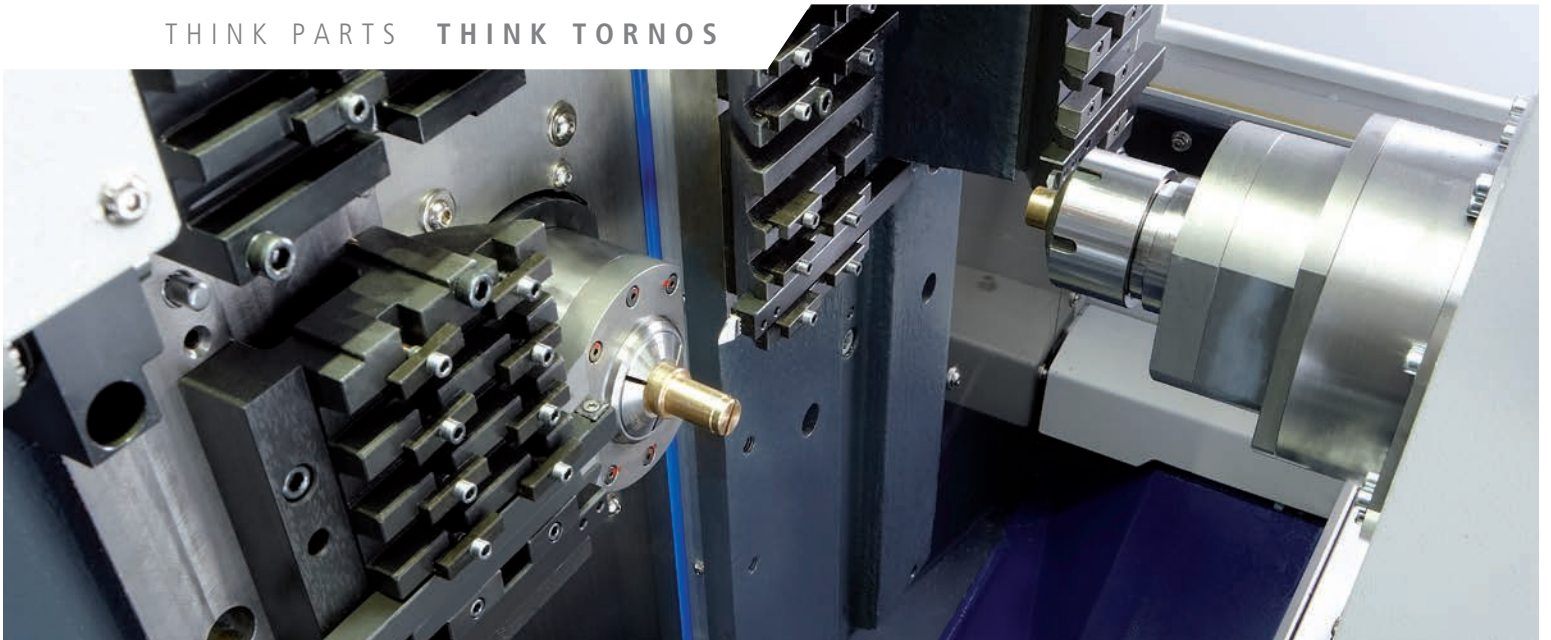

SWISS ST 26

High Performance Swiss Type Lathe

TORNOS PROVIDES SOLUTIONS TO HIGH-TECH INDUSTRIES SPECIALISING IN THE FOLLOWING SECTORS

AUTOMOTIVE



MEDICAL



ELECTRONICS

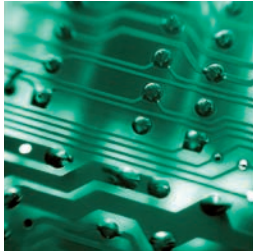

MICROMECHANICS



SWISS ST 26 IN A FEW WORDS

High performance Swiss type lathe



Productivity

- Up to 3 tools cutting simultaneously.
- The most dynamic spindles in its class.
- Balanced turning and milling operations are possible.



Performance

- Up to 25,4 mm capacity (with bar prep).
- The most powerful spindles in its class.
- Designed to work with or without guide bush.
- Unique modular tooling system.
- Up to 37 tools.



Accessibility

- Large work zone allowing easy access to the tools from both sides of the machine.
- Ergonomics designed with the operator in mind.
- Open design for excellent chip evacuation into the large chip container.

Machining example Swiss ST 26



Material: Al Eco62Sn 9 Ø 22 mm
Production: 43,2 sec/part
Double slide allowing simultaneous drilling in main operation.
Face burnished in counter operations.

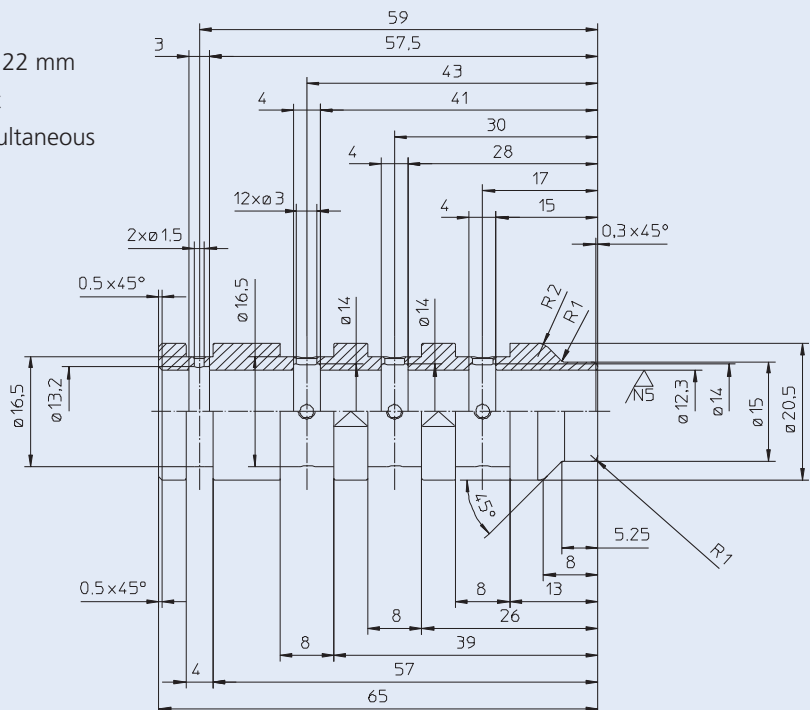
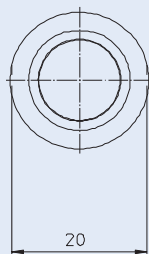

SWISS ST 26

High performance Swiss type lathe with modular tooling concept



Performance

- 23 mm capacity, up to 25,4 mm with bar end preparation.
- Up to 37 tools.
- Up to 20 rotating tools.
- Possible to work with or without guide bush.
- The 2 independent platens add flexibility and machinability for operations such as milling, slotting or balanced turning.
- The most powerful and dynamic main spindle and counter spindle in its class.
- Wide selection of attachments and accessories.

Productivity

- 2 completely independent tool systems allows optimisation of machining in main operations.
- 7 linear axes and 2 C axes.
- Highly dynamic spindles: 0 to 10 000 rpm in only 0,9 seconds.

SWISS ST 26



Accessibility

- Large machining area accessible from both sides of the machine.
- Ergonomic design.
- Control panel is mounted on a swivelling arm for easy access.
- Unique modular tooling system.

Autonomy

- Open design for excellent chip evacuation.
- Large coolant tank.
- Large chip container allowing for extended running.
- Automatic central lubricating system.

SWISS ST 26

DELIVERING HIGH TECHNOLOGY

New motor spindle technology

- 100% Swiss design and manufacture by Tornos in Moutier, Switzerland.
- Identical main spindle and counter spindle with high performance synchronous motors.
- Heat exchanger keeps the spindles thermally stable assuring high precision.
- Powered spindles offer high output and high torque.
- Reduction in idle time (stopping, indexing, acceleration, deceleration), from 0 to 10 000 rpm in 0,9 sec.
- Reduced noise and maintenance.
- Best power in its class.

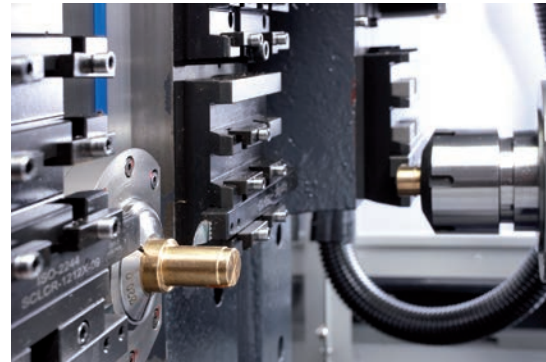

Working with or without a guide bush

- Possible to switch between the guide-bush type and guide-bushless type, the most suitable system for the part can be chosen.
- Quick change over in less than 30 min.
- Lower quality bar material required and shorter bar end (short bar remnant).

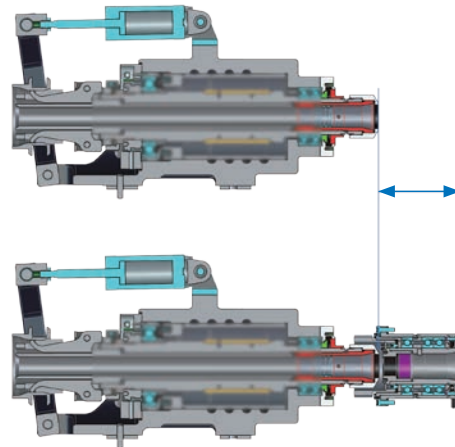

«Done in one»

Finish the part! This has been the challenge for Tornos engineers since the company was founded.

We have constantly introduced innovative machining solutions in order to avoid secondary operations.

For example :

- Internal and external thread whirling
- Gear hobbing
- Torx milling
- Deep boring
- Angled milling for main operations and counter operations
- Thread cutting
- Thread rolling
- Stamping
- Roller burnishing
- Micro milling with high frequency spindles

SWISS ST 26

EXTREME MACHINING CAPABILITIES

Ergonomics

The wide machining area enables the operator to access the tools easily for short setup times. User friendly thanks to the latest Fanuc control, embedded in an ergonomic panel, and mounted on a swivelling arm that can be accessed from both sides of the machine.



Un-manned operation

To improve the machine's profitability, the Swiss ST 26 has been designed to run unattended for long periods of time with no human intervention.

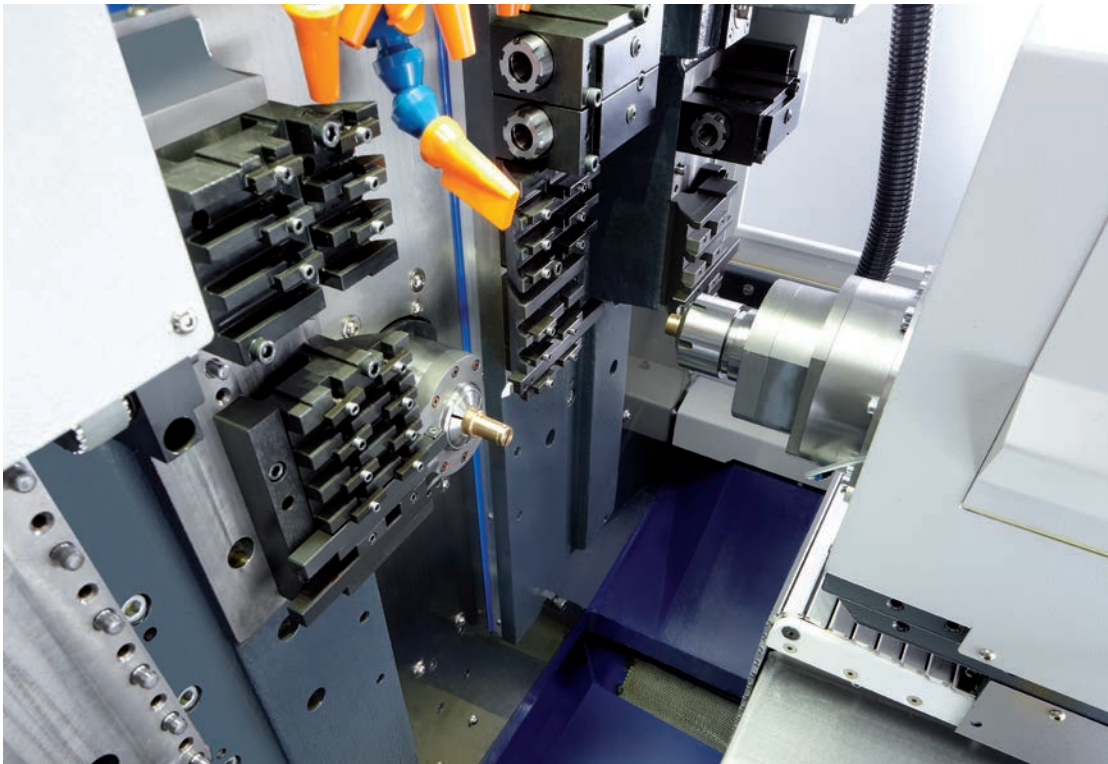

MODULAR TOOLING CONCEPT

Swiss ST 26 is available in 3 packages all feature:

- Unique modular tooling arrangements allow machine to accommodate value added operations like polygon turning, thread whirling, deep drilling, etc.
- 7 axes with 2 independent tool platens, 37 tool positions.
- Up to 20 positions can accept rotating tools.
- Every Swiss ST package includes the C axis in main (C1) and counter operations (C4).

■	Tool platen 1
■	Tool platen 2
■	Counter operations
■	Counter spindle



■ Thread whirling unit
 max. 5 700 min⁻¹
 angle +/- 15°
 Ø max. 10 mm



■ Polygon milling unit
 max. 6 000 min⁻¹
 polygon tool Ø 80 mm



■ ■ ■ Tool holder for 3 turning tools for counter operation



■ ■ ■ Tool holder for 2 turning tools

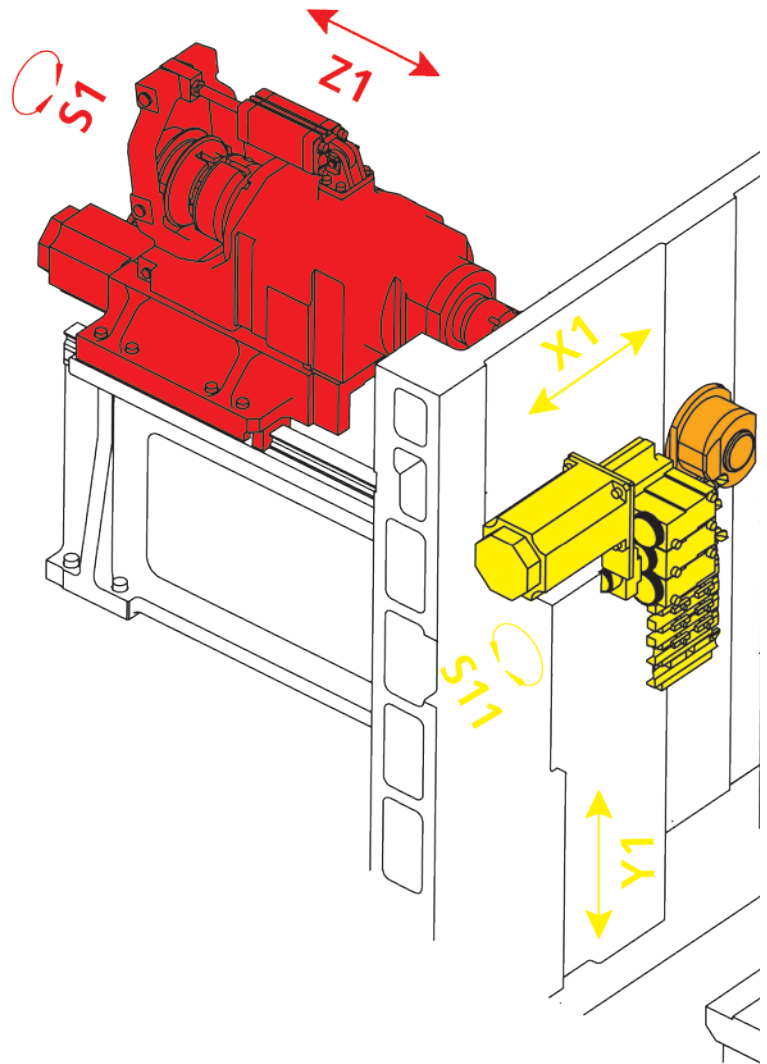

THE GUARANTEE OF HIGH FLEXIBILITY





 Tool holder for 5 turning tools



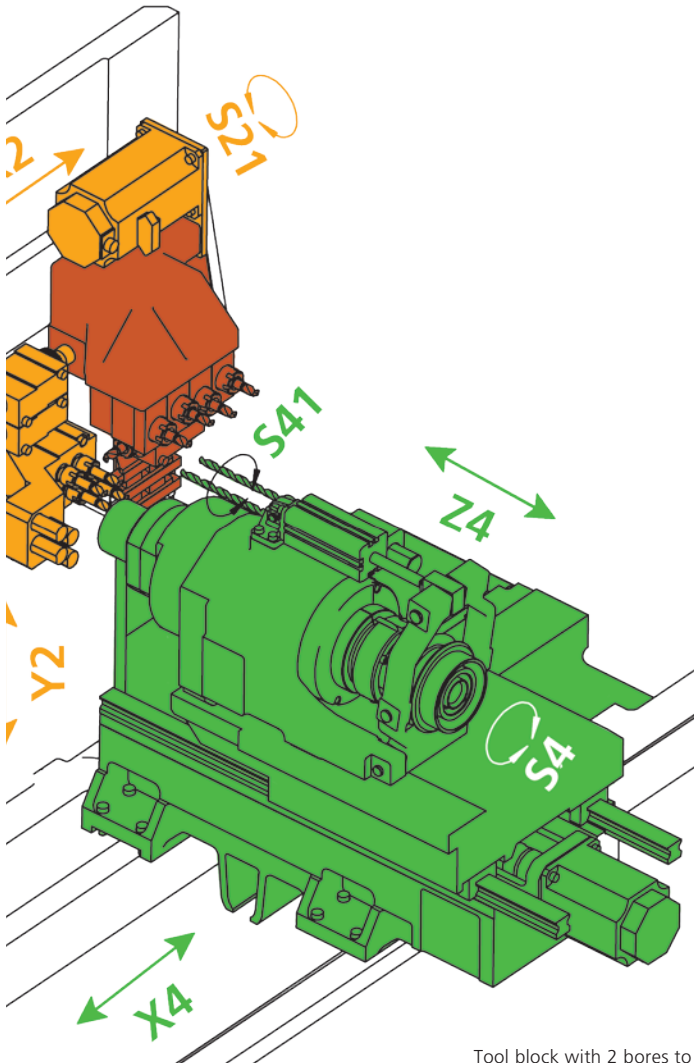

 Tool holder with 2 end working positions





 Drill/milling attachment with ESX 20 collet (6 mm offset)

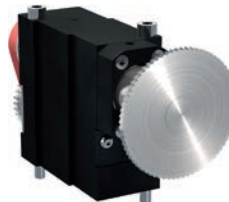



 Drill/milling attachment with spindle for ESX 20 (15 mm offset)





 Milling attachment (63 mm saw)



 Base with 3 bores to accept steady holders for work in counter operations



 Offset tool block with 8 bores to accept holders for work in main (4x) and counter operations (8x).

Tool block with 2 bores to accept drill holders for deep drilling. Mounts on the left side of the counter spindle. Maximum drilling length: 160 mm. Fitted with connection for high pressure coolant.



SWISS ST 26

Swiss type lathe with 7 linear axes

Z1	C1	S1			
Sliding headstock	Sliding headstock C axis	Main spindle			
X1 / Y1		S11			
Platen 1		Rotating spindle on guide bush			
X2 / Y2		S21			
Platen 2		Rotating spindle on guide bush			
X4 / Z4	C4	S21	S4	S41	
Counter spindle	Counter spindle C axis	Rotating spindle on counter operations	Counter spindle	Rotating spindle on the counter spindle slide	

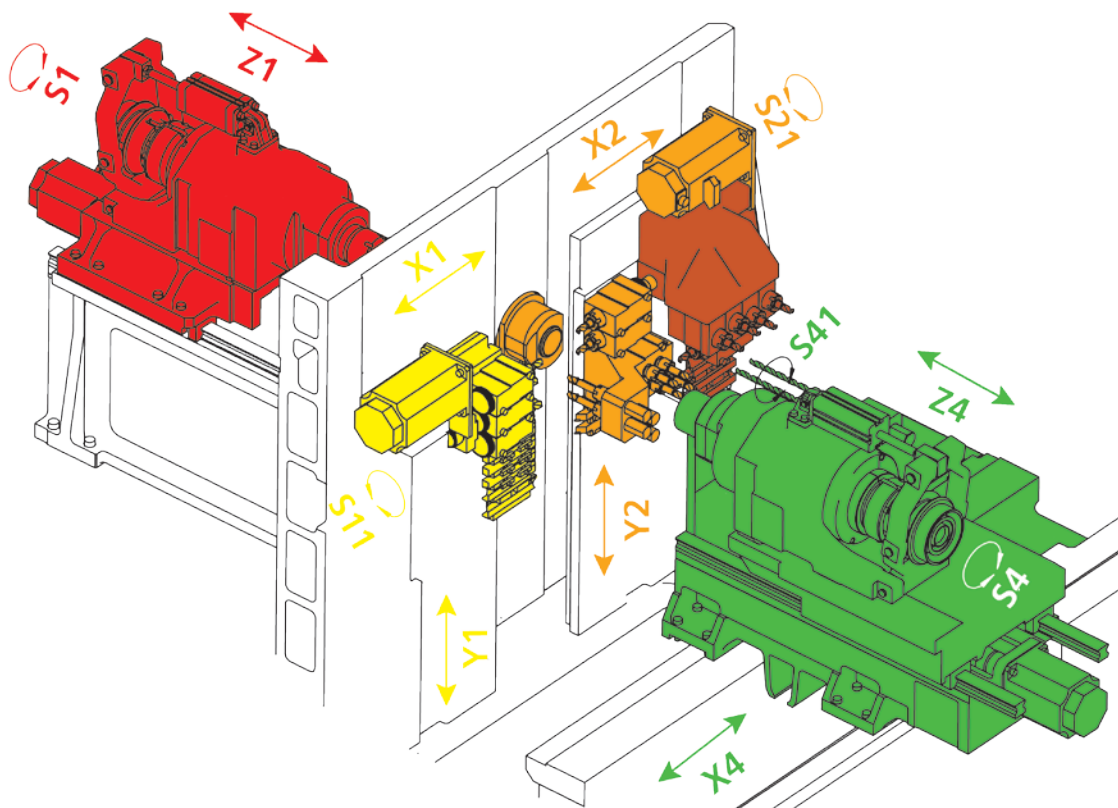

TECHNICAL SPECIFICATIONS

SWISS ST 26

7 linear axes + 2 C axes
2 independent tool systems

Main Spindle (headstock) (Z1/S1/C1)

Maximum bar capacity	mm	23 (25,4)
Standard part length with a rotating guide bushing	mm	220
Max. rpm of the spindle	rpm	10 000
Spindle output	kW	9,5 (11)
Max constant torque	Nm	17
Spindle stop or start time from 0 to 10 000 rpm	sec	0,9
Drilling capacity in free machining steel	mm	10
Tapping capacity in free machining steel		M10

Tool platen (X1/Y1/S2) (X2/Y2)

Number of tool positions in main operations		18
Cross section of the turning tools		12 x 12 mm or ½ x ½
Number of positions for rotating tools		8
Max rpm of the rotating tools	rpm	6 000
Output of the rotating tools	kW	1
Drilling capacity in free machining steel	mm	8
Tapping capacity in free machining steel		M6

Counter spindle (X4/Z4/S4/C4)

Maximum bar capacity	mm	23 (25,4)
Max. rpm of the spindle	t/min	0 to 10 000
Spindle output	kW	9,5 (11)
Max constant torque	Nm	17
Spindle stop or start time from 0 to 10 000 rpm	sec	0,9
Drilling capacity in free machining steel	mm	10
Tapping capacity in free machining steel		M10
Maximum number of tools		37
Breakdown of tools between main and counter operations		20 / 17
Type of control		Fanuc 31i-B
Feedback of the motor-encoder axes		Absolute pulse encoders
Type of motors (axes and spindles)		synchronous (AC)
Resolution of the axes	µm	0,1

NC SPECIFICATIONS

Item	Description
NC unit	Fanuc 31i-B
Controllable axes	X1, Z1, Y1, X2, Y2, C1, X4 (XB), Z4, C4
Least input increment	0,0001 mm
Interpolation method	Linear / circular
Rapid traverse rate	35 m/min Y1, Y2; 30 m/min Z1, X4, Z4; 20 m/min X1, X2
Cutting feed rate	1 to 6,000 mm/min
Feed rate override	0 to 150%, 10% step
No. of tool offsets	100
LCD/MDI	10,4" Color LCD
Part program storage size	1 Mb

SWISS ST 26

GENERAL SPECIFICATIONS

Max. length	mm	2778
Max. width	mm	1200
Height	mm	2304
Weight	kg	3720
Coolant tank capacity	l	220 (+80)
Power of the coolant pump	W	1000
Max. pressure	bars	3
Max output of the coolant pump	l/min	80
Colours : RAL 9006 grey, RAL 9011 black		

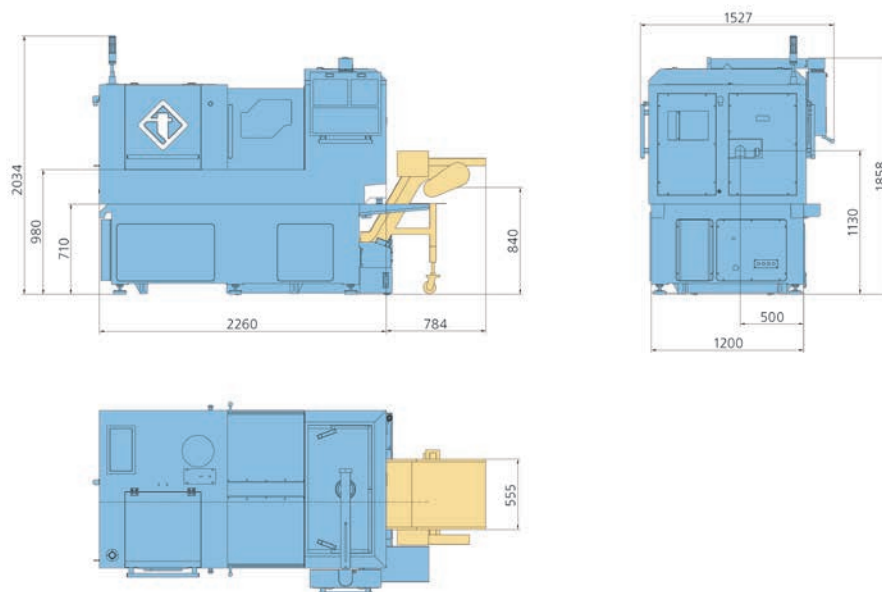

BASE MACHINE EQUIPMENT

Rotating guide bushing	x
S1 motorisation for rotating tools on the front tool platen	x
S2 motorisation for rotating tools on the rear tool platen	x
S4 motorisation for the rotating tools in counter operations	x
Axes C1 + C4	x
Pneumatic part ejector + cleaning of the counter spindle collet with coolant	x
Central lubrication system	x
3 colors light tower	x
Coolant pump with self cleaning filter	x
High pressure pump, 20 bars – 20 l/min	x
High pressure pump, 60 bars – 20 l/min	option
Timer to pre-heat the coolant	x
Interface for a fire-fighting device	option

MAIN STANDARD NC FUNCTIONS

Ethernet
USB
Rigid tapping
Constant surface speed control
Spindle synchronous control
Direct drawing dimension (DDD)
Custom macro
Chamfering/corner R
Inch/metric conversion
Multiple repetitive cycles
Tool radius – Tool nose radius compensation
Tool geometry / wear compensation
Background editing
Manual handle retrace
Canned cycle drilling
Run time/parts number display

WHICHEVER SWISS ST YOU CHOOSE : YOU ALWAYS CHOOSE SWISS MADE QUALITY

STARTER PACK



Main operation

- Tool holder for 5 turning tools
- Tool holder for 3 turning tools
- Offset tool block with 8 bores to accept holders for work in main (4x) and counter operations (8x)
- 3 drill/milling attachments with ESX 20 collet
- Tool block with 2 bores to accept drill holders for deep drilling; mounts on the left side of the counter spindle

Counter operation

- Tool holder for 3 turning tools
- 2 tool holders for end working positions with ESX 20 collet

ADVANCED PACK



Main operation

- Tool holder for 5 turning tools
- Tool holder for 3 turning tools
- Offset tool block with 8 bores to accept holders for work in main (4x) and counter operations (8x)
- 5 drill/milling attachments with ESX 20 collet
- Tool block with 2 bores to accept drill holders for deep drilling; mounts on the left side of the counter spindle

Counter operation

- Tool holder for 3 turning tools
- 2 tool holders for end working positions with ESX 20 collets
- 5 drill/milling attachments with ESX 20 collets

MEDTECH PACK



Main operation

- Tool holder for 5 turning tools
- Tool holder for 3 turning tools
- Offset tool block with 8 bores to accept holders for work in main (4x) and counter operations (8x)
- 3 drill/milling attachments with ESX 20 collet
- 1 thread whirling unit
- Tool block with 2 bores to accept drill holders for deep drilling; mounts on the left side of the counter spindle

Counter operation

- Tool holder for 3 turning tools
- 2 tool holders for end working positions with ESX 20 collets
- 5 drill/milling attachments with ESX 20 collets

KINEMATICS

SWISS ST 26 STARTER PACK

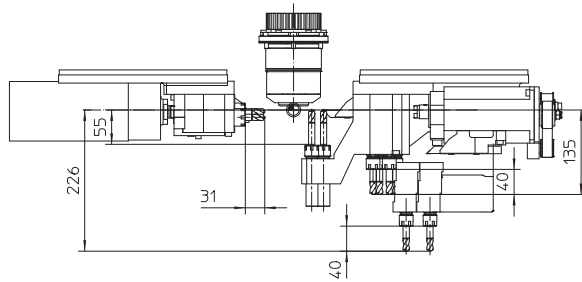
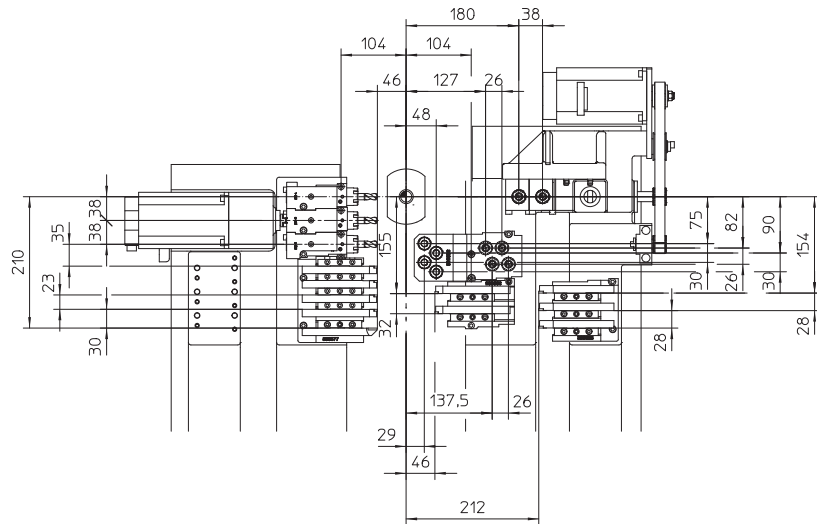

SWISS ST 26 ADVANCED PACK

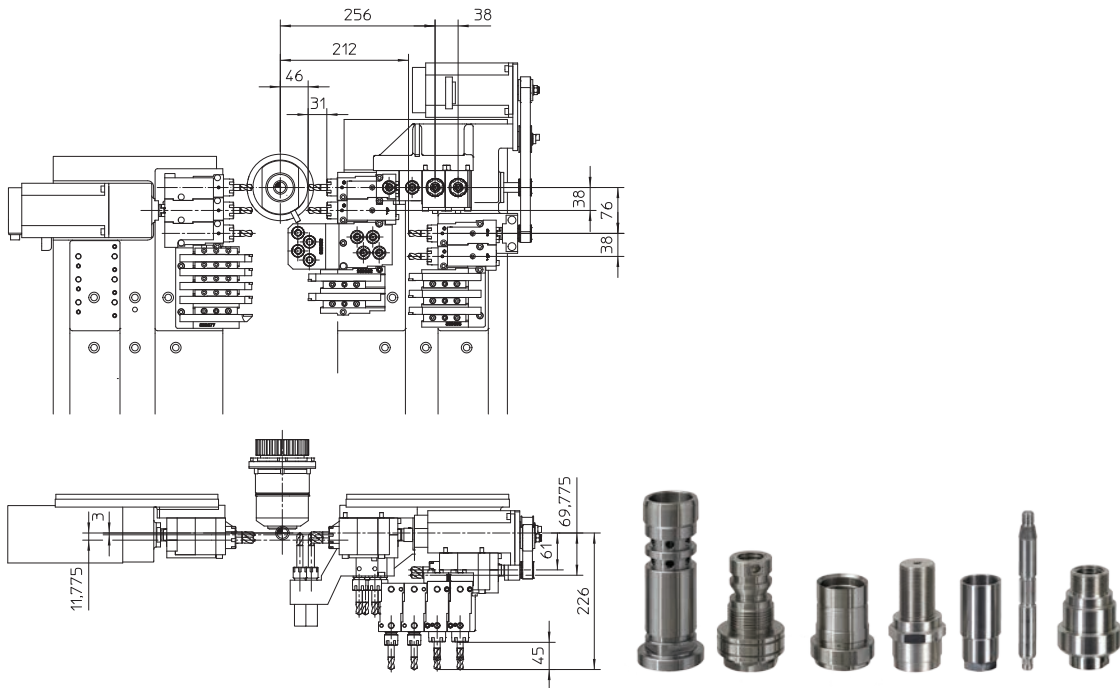

SWISS ST 26 MEDTECH PACK

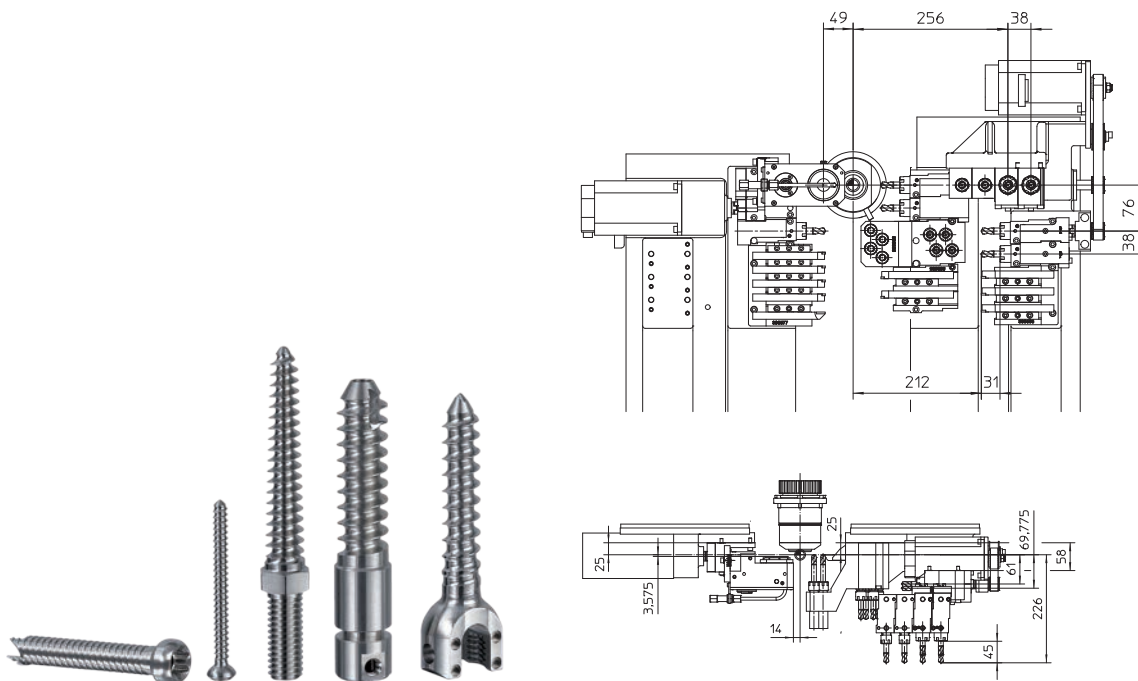

TORNOS SA

Rue Industrielle 111
CH- 2740 Moutier
T +41 (0)32 494 44 44
F +41 (0)32 494 49 03
contact@tornos.com
www.tornos.com

TORNOS TECHNOLOGIES

DEUTSCHLAND GmbH

Karlsruher Str. 38
D- 75179 Pforzheim
T +49 (0)7231 / 910 70
F +49 (0)7231 / 910 750
germany.contact@tornos.com

TORNOS TECHNOLOGIES

FRANCE

Boîte postale 330
St-Pierre en Faucigny
F- 74807 La Roche
s / Foron Cedex
T +33 (0)4 50 038 333
F +33 (0)4 50 038 907
france.contact@tornos.com

TORNOS TECHNOLOGIES

IBÉRICA

Pol. Ind. El Congost
Avda. St Julià, 206 Nave 8
E- 08403 Granollers
T +34 93 846 59 43
F +34 93 849 66 00
comercial.tti@tornos.com

TORNOS TECHNOLOGIES

ITALIA SRL

Via Cesare Pavese 21
I- 20090 Opera / MI
T +39 02 57 68 15 01
F +39 02 57 68 15 230
italia.contact@tornos.com

TORNOS TECHNOLOGIES

US CORPORATION

840 Parkview Boulevard
US- Lombard, IL 60148
T +1 630 812 2040
F +1 630 812 2039
info-us@tornos.com
www.tornos.us

TORNOS TECHNOLOGIES

UK LTD

Tornos House
Whitwick Business Park
Coalville
UK - Leicestershire LE67 4JQ
T +44 (0) 1530 513100
F +44 (0) 1530 814212
sales@tornos.co.uk

TORNOS TECHNOLOGIES

POLAND Sp. z o.o.

Ul. Spółdzielcza 37-39
55-080 Kąty Wrocławskie
Poland
T +48 71 33 85 618
F +48 71 33 85 617
poland.contact@tornos.com

TORNOS TECHNOLOGIES

(Shanghai) LTD

Hui Feng Creativity Garden
Feng Yu Building, 1-2F
No. 239, Xitai Rd, Xu Hui District
CN- Shanghai 200232
T +86 21 6235 1235
F +86 21 6235 1938
china.contact@tornos.com

TORNOS BEIJING OFFICE

601 Unit2, Building 624
Guo Feng Shang Guan
Wangjing Chaoyang District
CN-BEIJING 100102
T +86 10 6477 9763
F +86 10 6477 9363
beijing.contact@tornos.com

TORNOS DONGGUAN OFFICE

SE1-29, Changrong Int. Machinery
Hardware Sq.
No. 56 Middle ZhenAn Road
Wusha, ChangAn Town
CN- Dongguan 523859
T +86 21 6235 1235
F +86 21 6235 1938
china.contact@tornos.com

TORNOS SA THAILAND

REPRESENTATIVE OFFICE

7th Floor, 19, Bangna -Trad Soi 34,
Bangna -Trad KM. 3 Road.
Bangna, Bangkok,10260
Thailand
T +66 2746 8840-1
F +66 2746 8842
thailand.contact@tornos.com

TORNOS TECHNOLOGIES ASIA LTD

MALAYSIA

REPRESENTATIVE OFFICE

No. 1-1-11, Ground Floor & 1-2-11,
First Floor, One Terrace Plus,
Tingkat Mahsuri 4,
11900 Bayan Lepas,
PENANG, MALAYSIA
T +60 4 642 6562 / 4 642 6563
F +60 4 642 6561
malaysia.contact@tornos.com