

Innovative HydroTurn Transforms Rotary Transfer Technology

With the announcement of the HT 32-12 CNC, the first of a revolutionary, ultra-precise HydroTurn Series of rotary transfer machines, Hydromat challenges conventional thinking in precision machining. What sets the HT Series apart is the incorporation of a sliding headstock at the infeed station, permitting Swiss-type turning of the rotating bar stock prior to cutoff and clamping. The result: superior part concentricity, ultra-precise diameter control and consistent surface finishes.

In effect, the patent-pending HydroTurn design combines the best capabilities of both sliding headstock and rotary transfer machine technologies and provides an entirely unique manufacturing solution.

According to Hydromat Director of Manufacturing Martin Weber, the HT design presents an array of advantages. “This is an approach not seen elsewhere in rotary transfer technology,” Weber says. “A not-so-obvious but very significant advantage of combining a sliding headstock with the proven rigid clamping of a Hydromat is that users who previously bought ground bar stock to produce very precise parts can now buy less

expensive drawn bar stock. Further, the need to handle bar stock with special care or packaging is eliminated.”

Weber explains that with the ability to do Swiss-type turning at the infeed station stock can be over-turned for better OD dimensional and roundness control, eliminating the OD variability associated with cold drawn bar stock while also providing better roundness than ground bar stock. The benefit is that each part clamped subsequent to the first will have the same exact, precise OD tolerances, part after part after part.

Other advantages of incorporating Swiss-type turning at the infeed station include the ability to do additional operations in the lathe station — heavy recessing and turning and single-pointing — all before the part is cut off and clamped.

“This actually expands the capacity of the 12-station machine, offering more operations than previously possible, further reducing the need for secondary operations and opening up the potential for a wider variety of applications and more complicated parts,” says Weber.

Further, the rotating bar

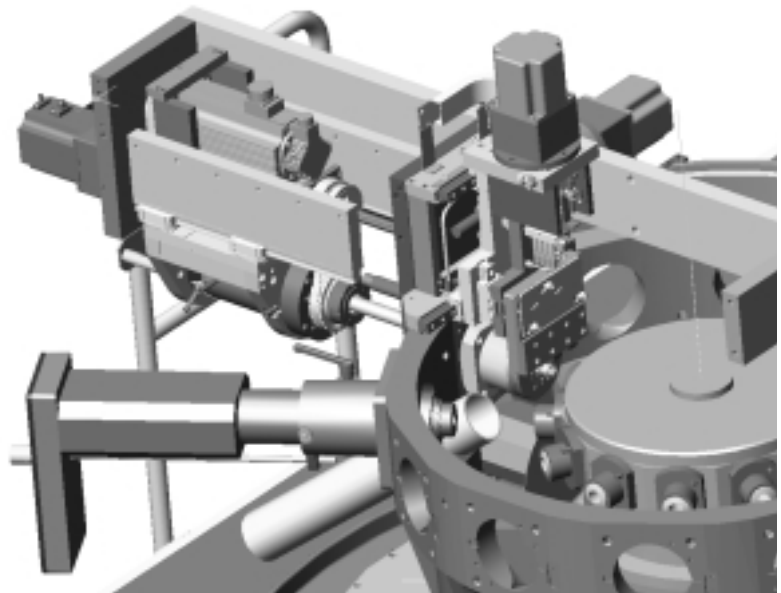

stock can be used to reduce cutoff time. Weber: “When we cut off a stationary part, we’ve got to cut off the *whole* part. With a rotating part, however, we can cut 2/3s into the radius. Then we move the bar stock through the collet and into the first clamping station. Once it’s clamped, we cut through the remaining material. Cutoff in two steps ensures precise alignment and takes less time.”

The HT 32-12 utilizes an entirely new casting design to accommodate the sliding headstock. An IEMCA BOSS 542 bar feeding system, with a special telescopic nose for infeeding bar to the sliding headstock, is standard. Rotating bar stock is fed through a rotating collet to an air- and hydraulically-activated guide bushing. The stationary guide bushing rotates with the bar and is driven by a timing belt synchronized with the 5000

(max) RPM air-cooled main spindle.

With a 32 mm capacity, the HT 32-12 is ideally suited to produce high precision parts from standard bars up to 12 ft long. Spindle bore is 37 mm. Headstock stroke is 200 mm. Ball screws drive the X, T and Z axes. Rapid feed rates are 20 m/min (Z-axis); 15 m/min (X-axis) and 15 m/min (T-axis). The main spindle is powered by a beefy 5 Kw AC servomotor. X-, Z-, and T-axes drives are powered respectively by 1.5 Kw, 0.75 Kw and 0.75 Kw AC servomotors.

The sliding headstock tooling package consists of quick-change gang tooling with four 19 mm (3/4”) toolholders — one to cut off the bar (which in some applications can be used to turn other features) and three additional tools for recessing, contouring, single-pointing and heavy turning. 



Committed To Excellence