

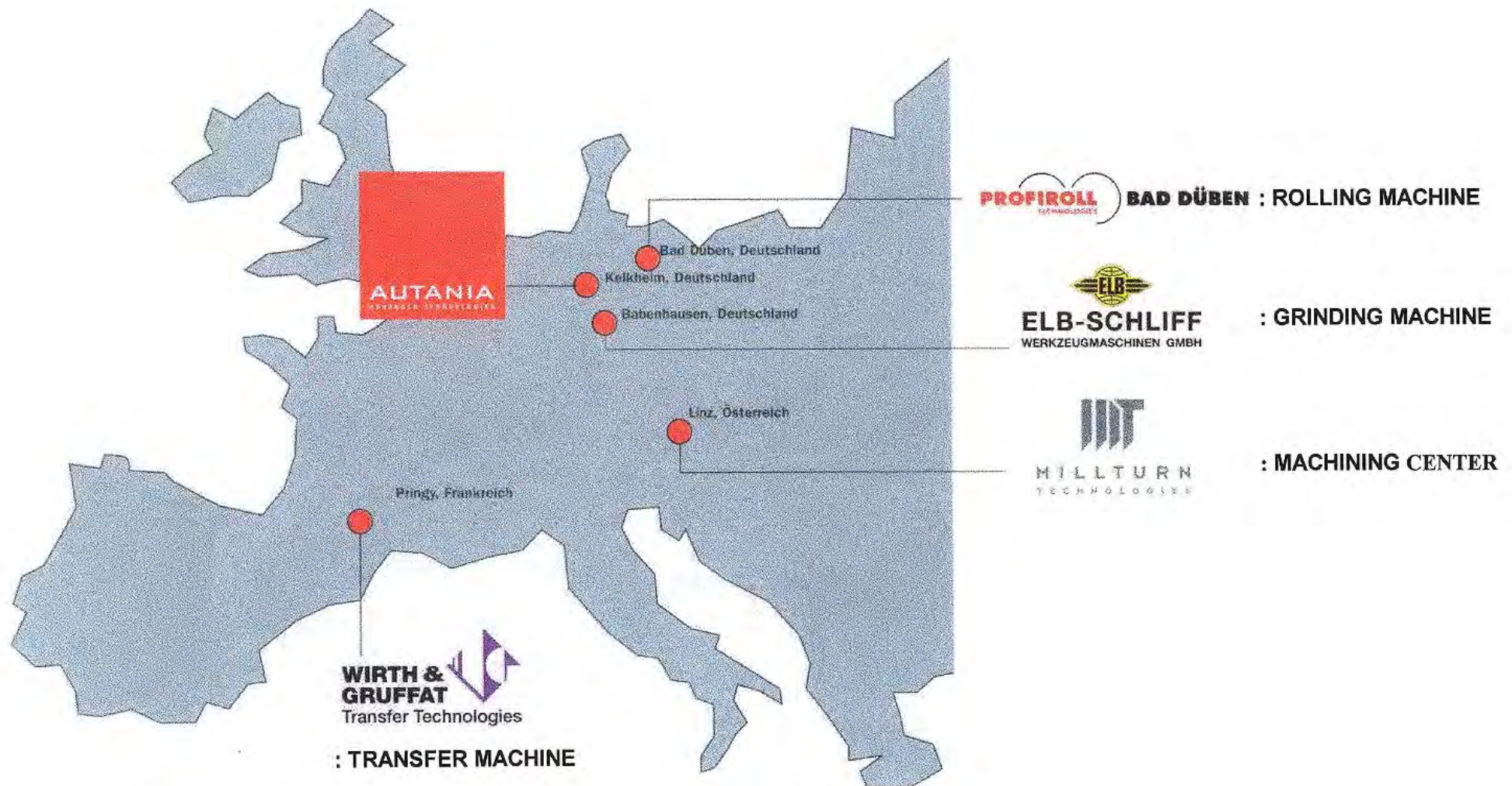

WIRTH GRUFFAT

Transfer Technologies





- 18 -

GROUP TURNOVER 120 Mi € (EXPORT 65%)

EMPLOYEES 750 p.

Company

- WG was established in 1945
- State of the art 10,000 sq. meter manufacturing facility located in Annecy France
- 155 employees
- The first transfer machine was built in 1971
- There are over 1,500 machines in service world wide.
- Approximately 250 machines in the US



Industries Served

Automotive
Electrical
Plumbing
Valve
Lock
Small engine
Hydraulic and pneumatic



Transturn TT 312 Transturn TT 306

6 and 12 Station Precision
Transfer Machines

Transturn TT-306 / TT-312



Machine Overview

The Transturn TT-312 is a 12 station transfer machine with 11 working stations and 1 loading station. Loading can be either a fully automatic bar loader with a maximum capacity of 42.00 mm diameter or with a 6 axis robot when loading castings or forgings. The index table is equipped with 12 cartridge type electrospindles capable of 6000 RPM and a full C axis. Each spindle is machined with a standard N4° spindle nose for mounting HAINBUCH 32 and 42 collets or a hydraulic 3 jaw chuck.

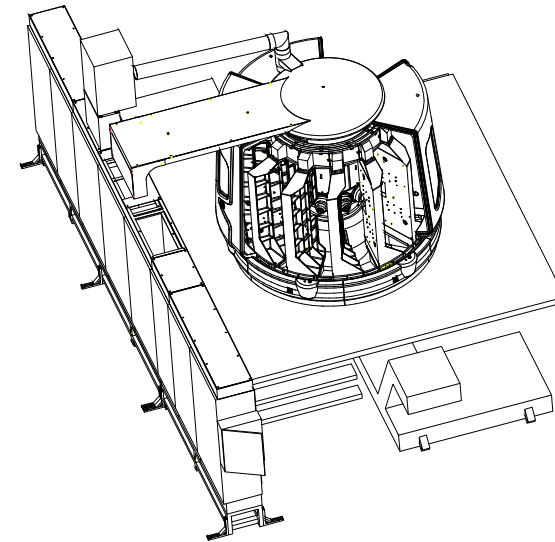

Each working station can accept two, 2 axis CNC cross slides, one located above the spindle the other located below. All slides are precision linear roller guides which are positioned via ball screw. The Tee slotted slides are designed to accept a variety of standard static tooling systems. Live spindles are mounted on the cross slides to perform operations such as cross drilling, milling and slotting. Both of the slides are mounted in a vertical configuration for optimal chip flow.

Base Machine Description

- Rigid weldment
- Machine weight 14 metric tons
- 11 vertical cross slide supports
- Complete Hydraulic System
- Electrical cabinet
- AC system for the electrical cabinet.
- Chilling unit for spindles.
- 16 Sq. meter machine platform.
- Safety rails.
- 6 panel telescopic machine enclosure
- Mist collector provision.
- Interior lighting system.
- Machine indicator light.

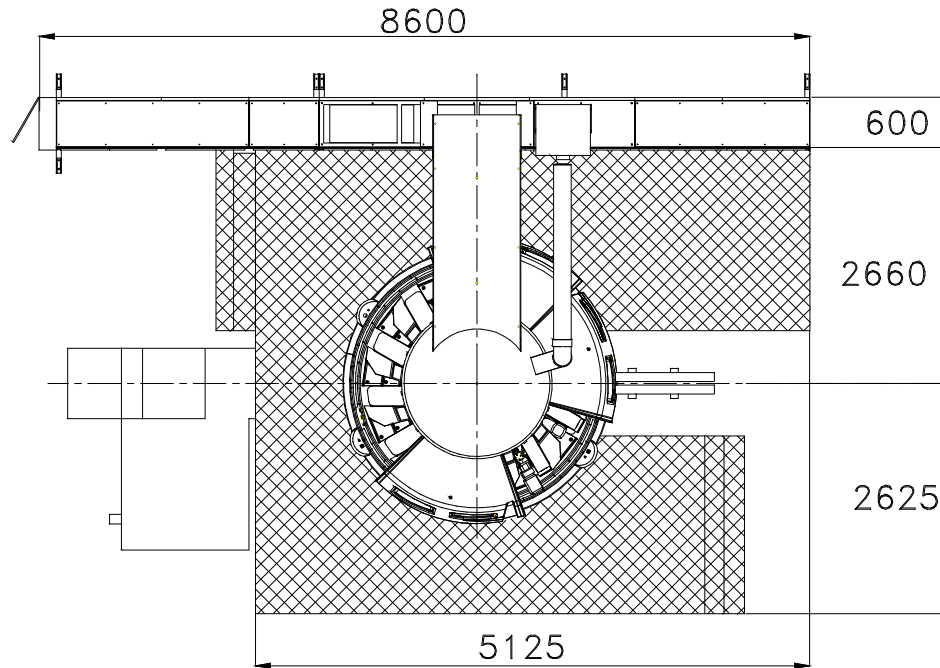

Index Table:

- Indexing and table location via 3 part Hirth coupling.
- Indexing accuracy +/- 3 seconds.
- Repeatability +/- 0.6 seconds (2.2 μ on $\text{Ø}1,500\text{mm}$)
- Fully programmable 12 divisions or subdivisions.
- Indexing time 1.5 seconds
- Rotary Hydraulic manifold for clamping circuit distribution.
- 2 individual pressures can be set at each clamping station.
- Collet flush manifold.
- Complete hydraulic interface.
- Complete electrical interface

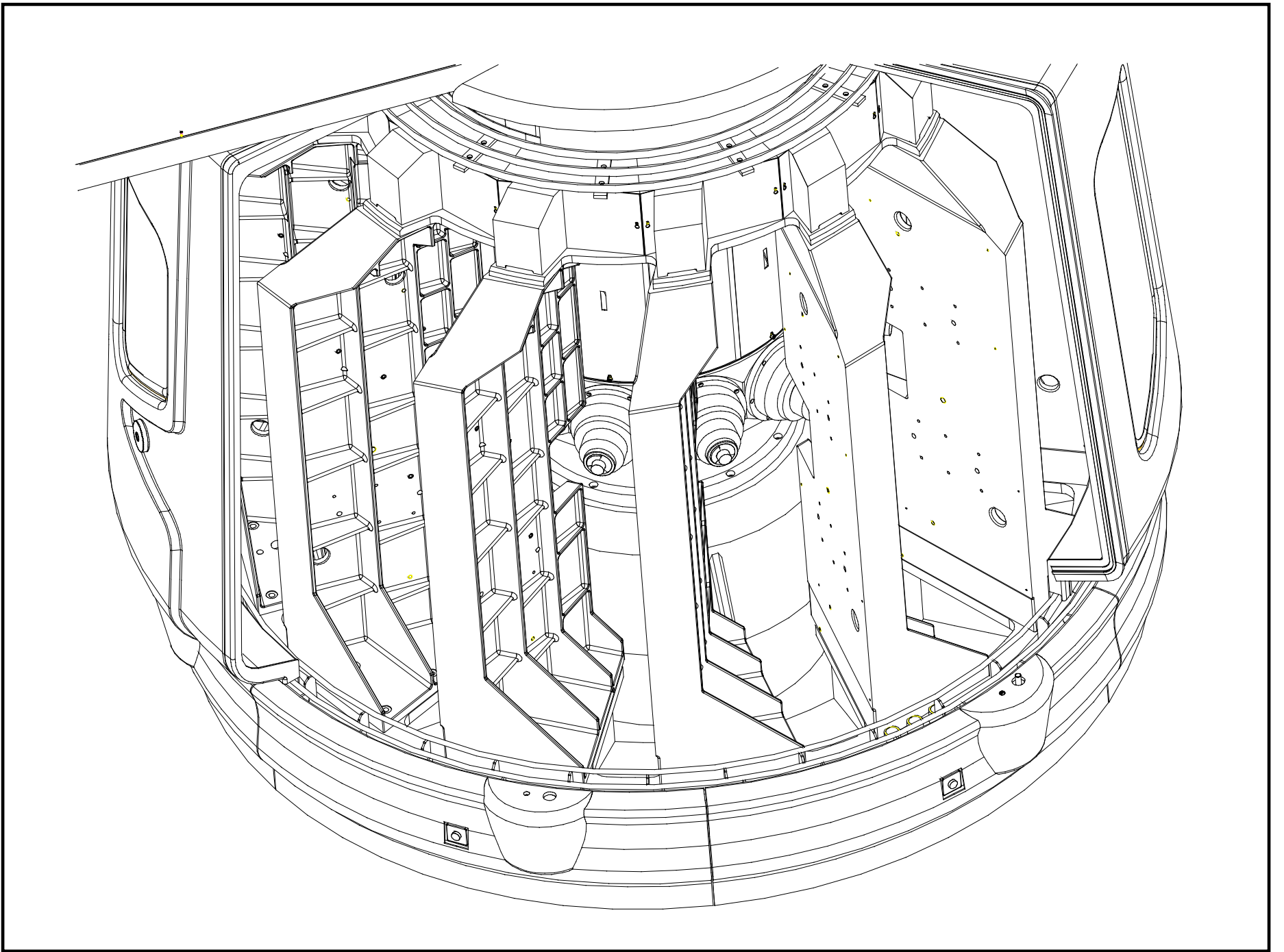

Clamping Table Spindles

- 12 individual spindles.
- Each spindle is driven via 10 Kw Bi-directional synchronous motor.
- 6000 RPM capability.
- 28 Nm torque.
- Acceleration 0 RPM – 6000 RPM , 0.5 seconds
- Fully programmable C axis.
- Indexing accuracy 2.0μ @ $\text{Ø}40.00$
- Each spindle is liquid cooled.
- N4° spindle nose for mounting HAINBUCH 32 and 42 collets or a Hydraulic 3 jaw chuck.

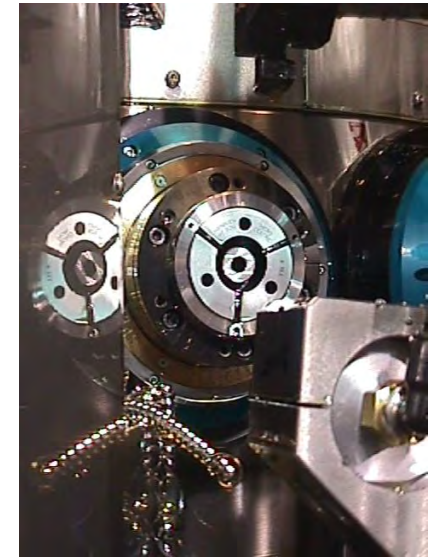
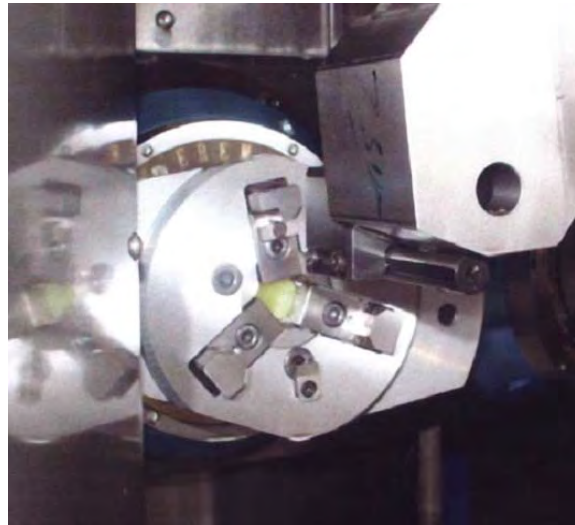
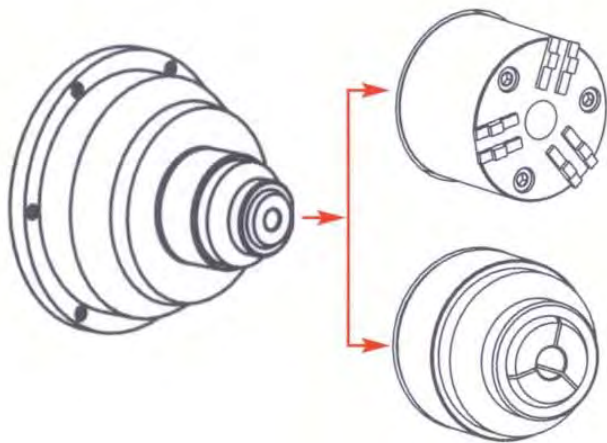
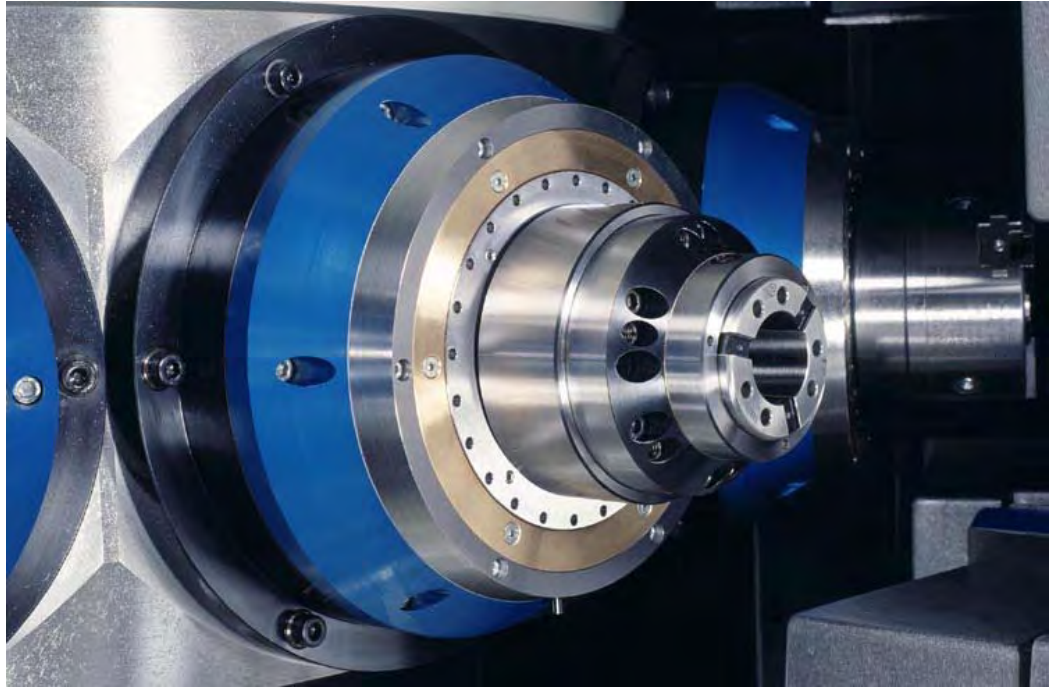

Hainbuch Collet Clamping System

Standard 32 or 42

Pull Type Actuation

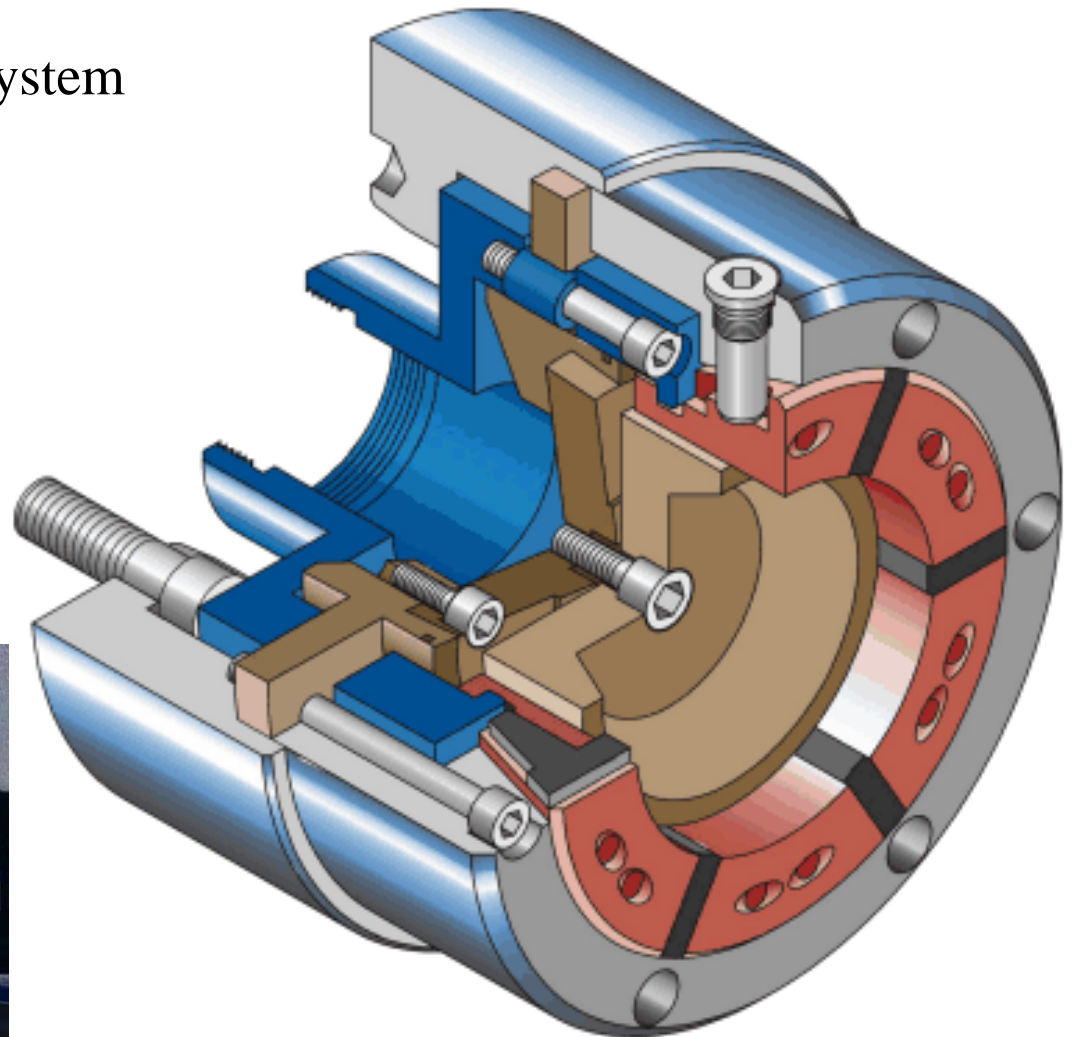
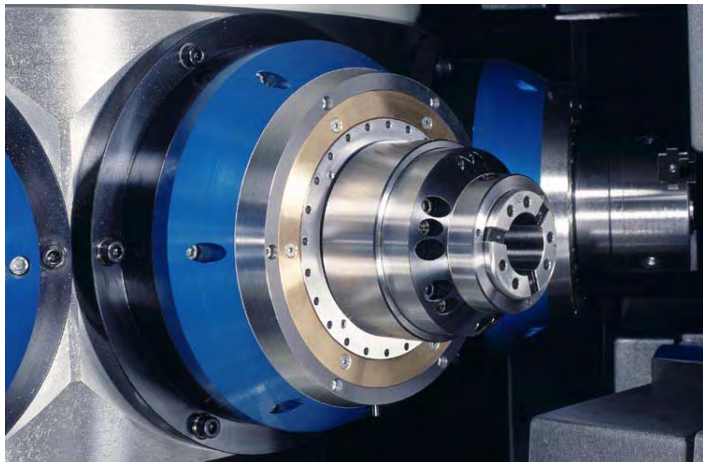

Motorized Spindle Cartridge

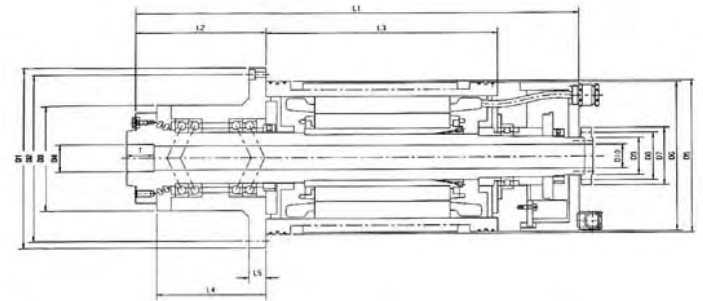

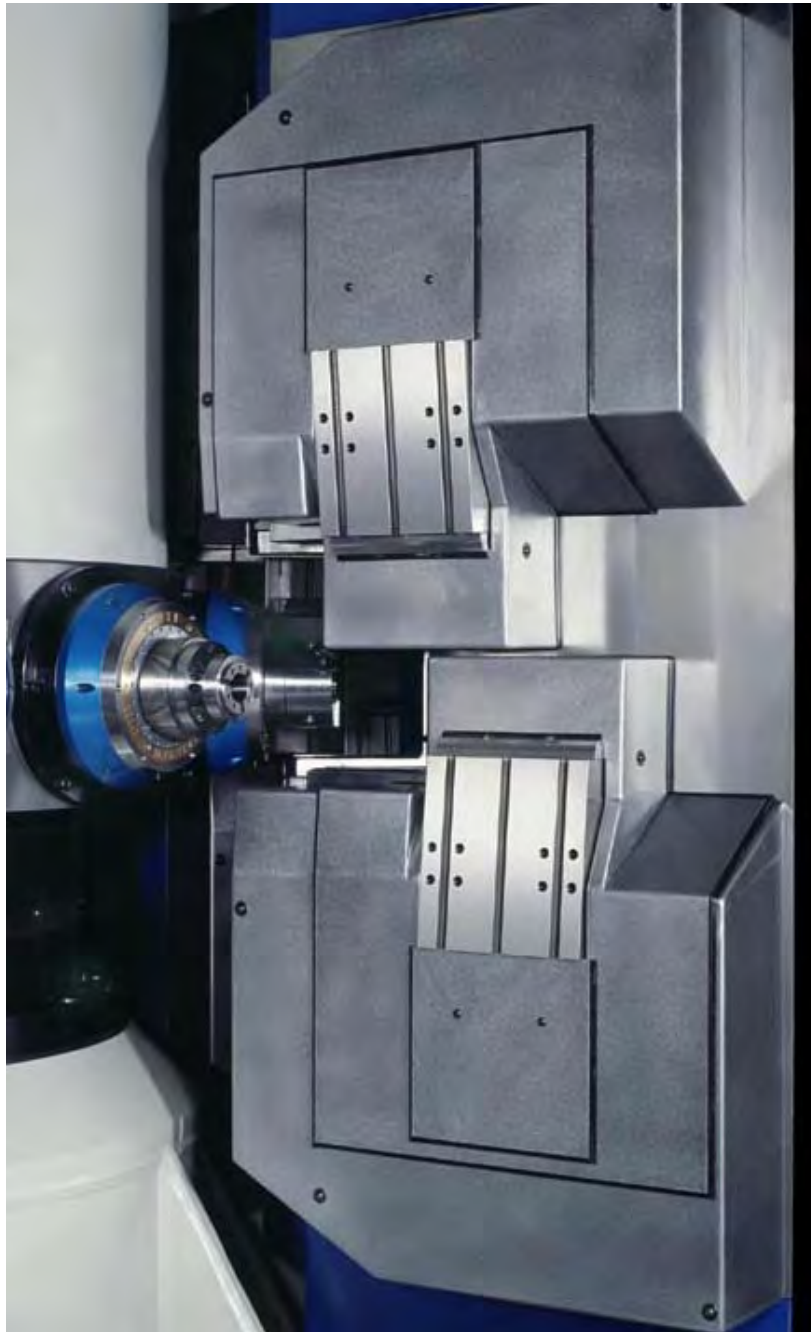

Cross-Slides:

- Numeric controlled: 2 axis slides.
- Stroke: X100 mm x Z100 mm.
- Siemens 1FT6 servomotors.
- Torque of motor axis: 4.3 Nm.
- Z axis thrust: 500 daN.
- Maximum linear speed: 10 m/min/ 400ipm.
- Positioning absolute encoder: 10 μ .
- Linear roller guides.
- Ball screws translation .
- Protected by liquid-tight telescopic covers.
- Central lubrication system.
- Complete electrical interface.



Machine Control

- Siemens 840D
- PCU 50 communications interface.
- Windows NT operating system
- Siemens OP010 operator control panel.
- 10.4" color screen.
- Hand held control with LCD display.
- Siemens 611D numeric converters.
- Control configuration is capable of operating 60 axes.

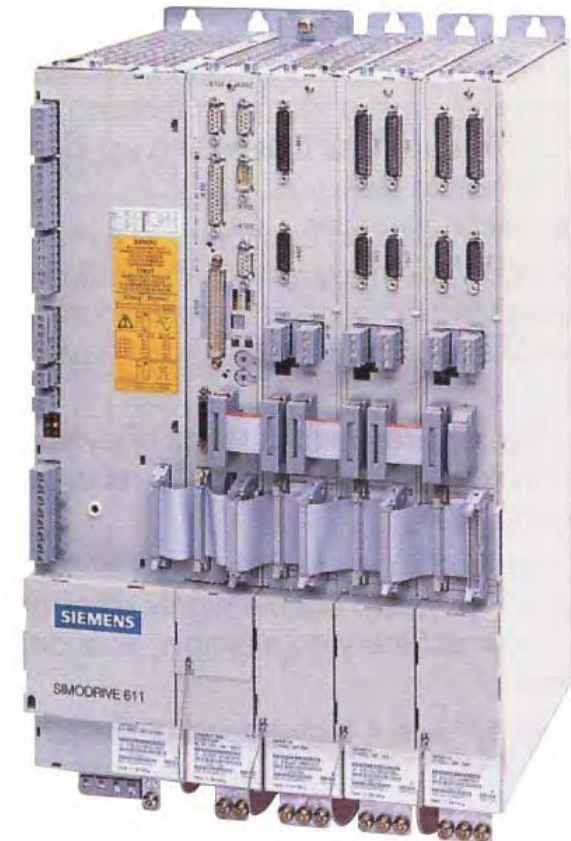

Various Loading Systems



5 Axis Robot



Bar feed capability
to 66mm diameter

Operational Sequence Rotor

Est. Cycle time: 18.3 Seconds

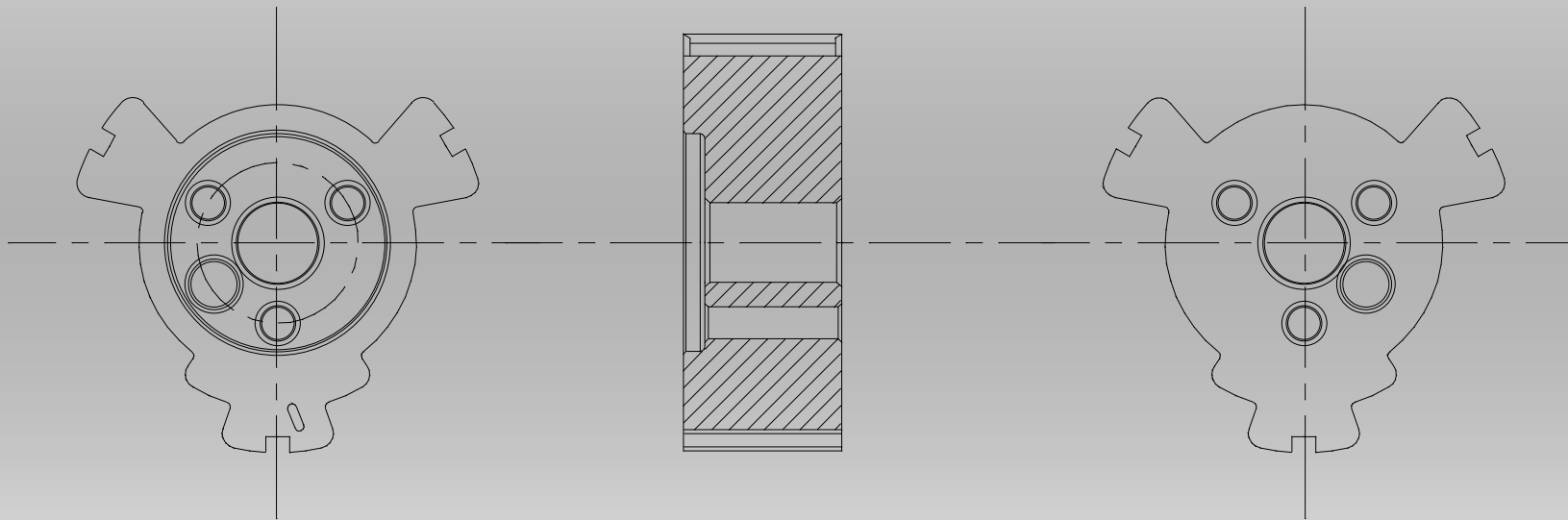

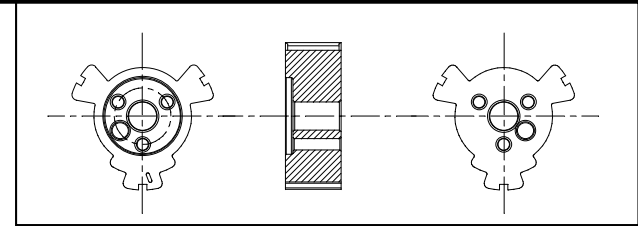

3 Jaw Self Centering Chucks

Robot Load /Unload Station 1

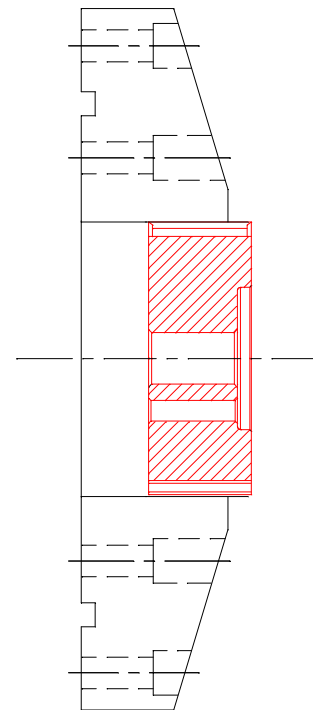
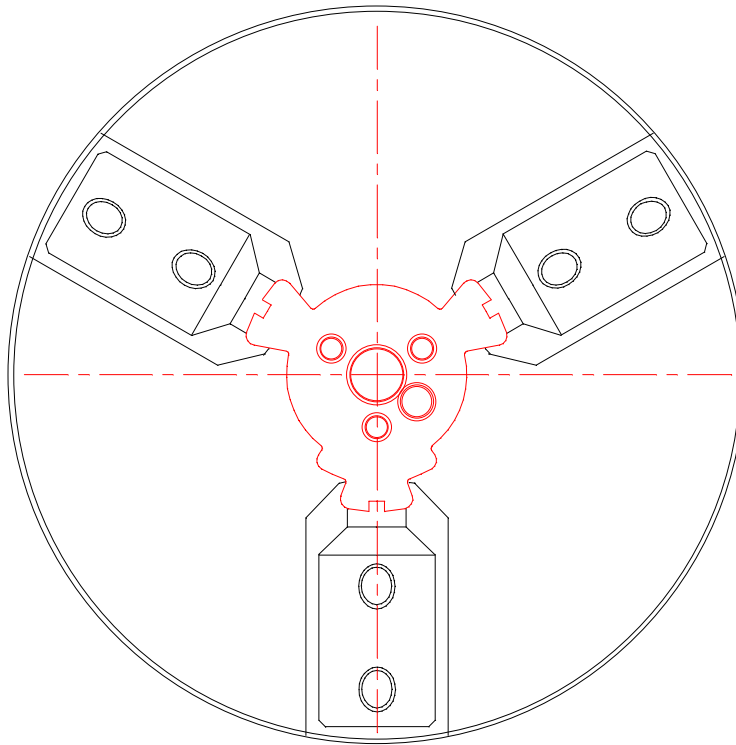

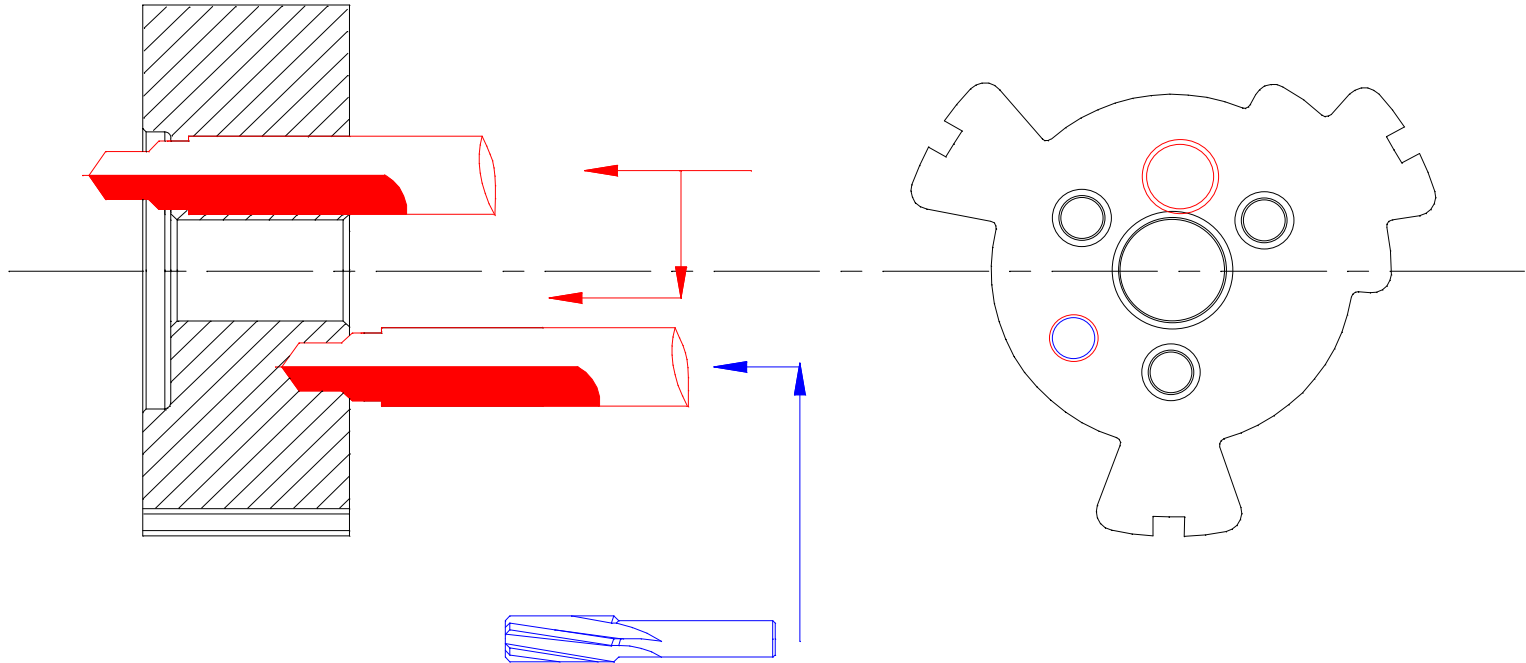
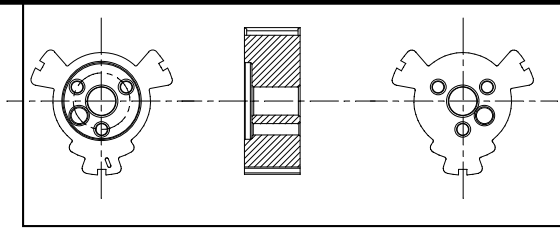

Station 2

Upper – Drill / Chamfer $\text{Ø } 3.8$ and Finish $\text{Ø } 10 \times 6.4$ (H- Driven Spindle)

Lower – Ream $\text{Ø } 4 \text{ mm } \# 15$ (H-Driven Spindle)



Station 3

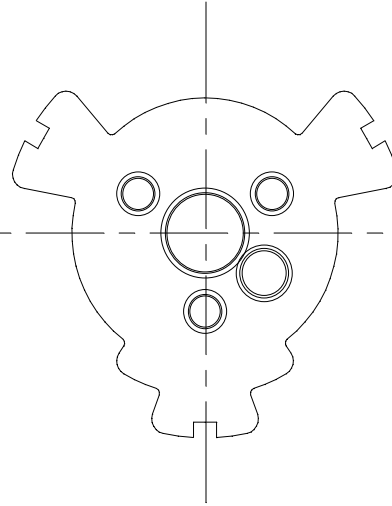
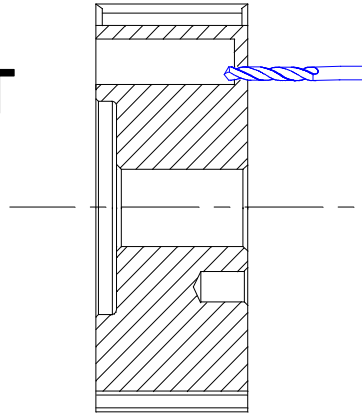

Upper – Drill thru \varnothing
2mm # 15
(H. Driven Spindle)

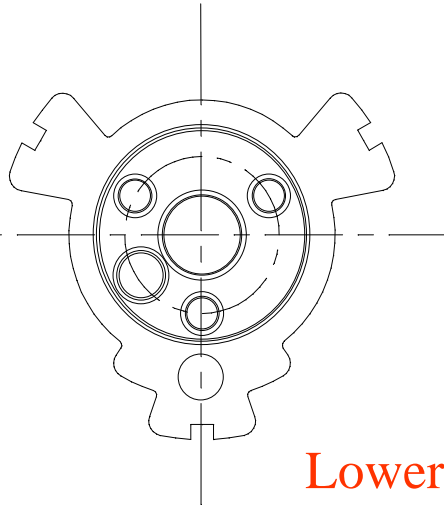
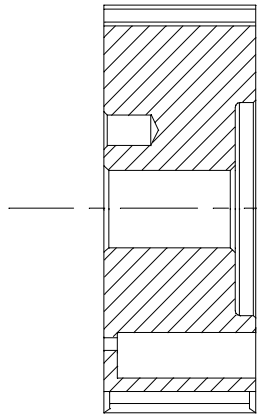

Lower – Invert Part 180°

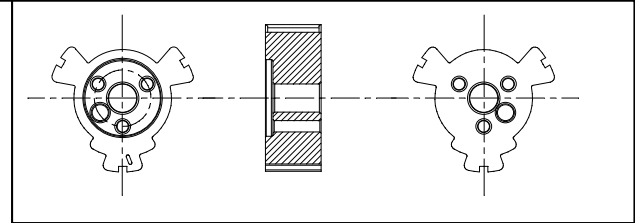

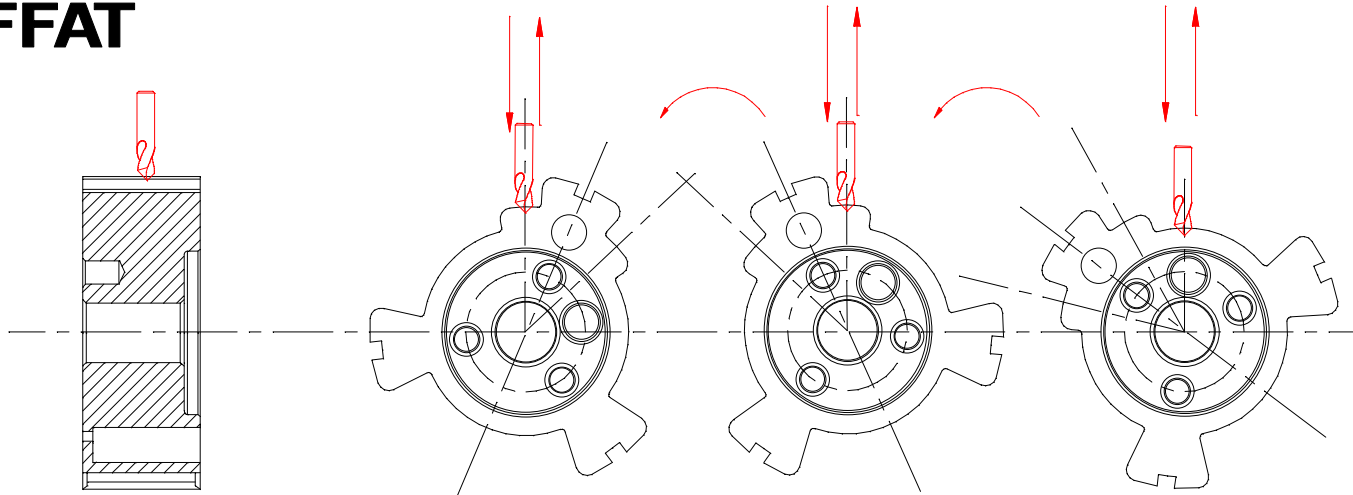

Station 4

Upper – Center Drill 2x for \varnothing 4.5, 1x for \varnothing 5 # 100,64,46

V. Driven Spindle

Lower – Drill \varnothing 4.5 # 46 (V.
Inverted Driven Spindle

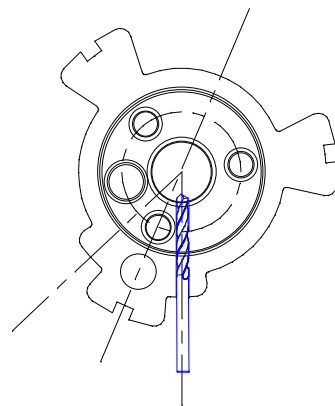

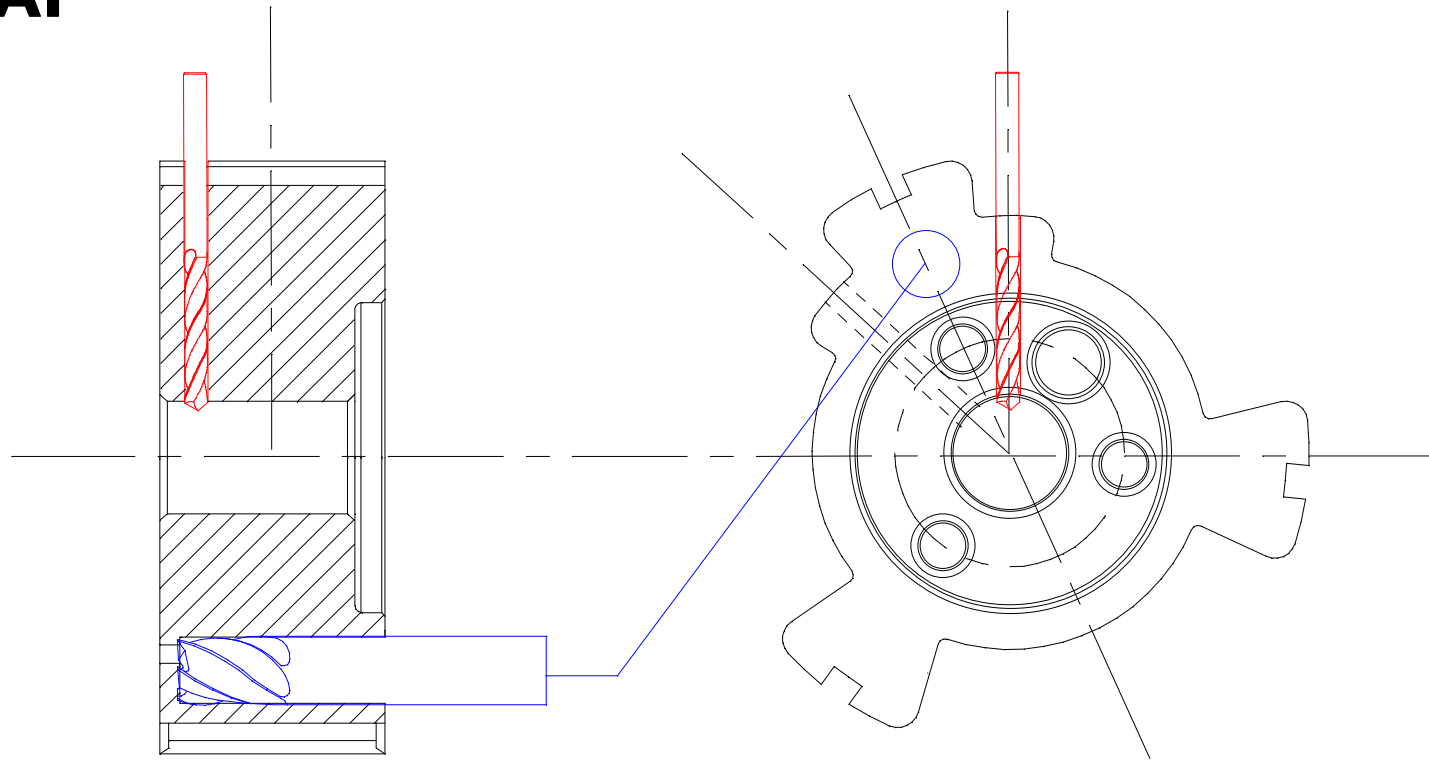
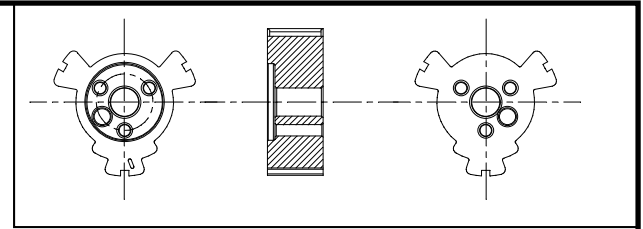

Station 5

Upper – Drill $\text{\O} 4.5$ # 64 (V. Driven Spindle)

Lower – Drill $\text{\O} 11.1$ # 69 (H. Driven Spindle)

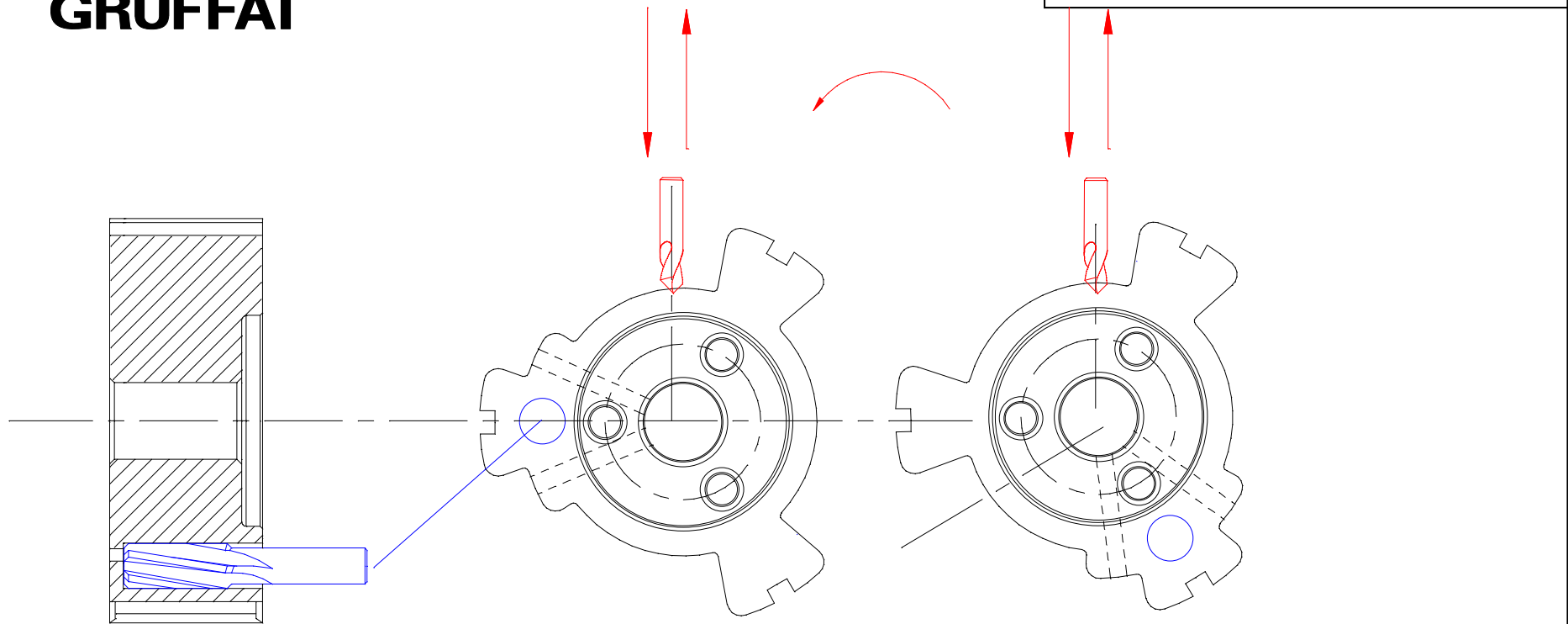

Station 6

Upper – Center Drill 2x # 48,50 (V. Driven Spindle)

Lower – Ream \varnothing 11.3 #69 (H. Driven Spindle)

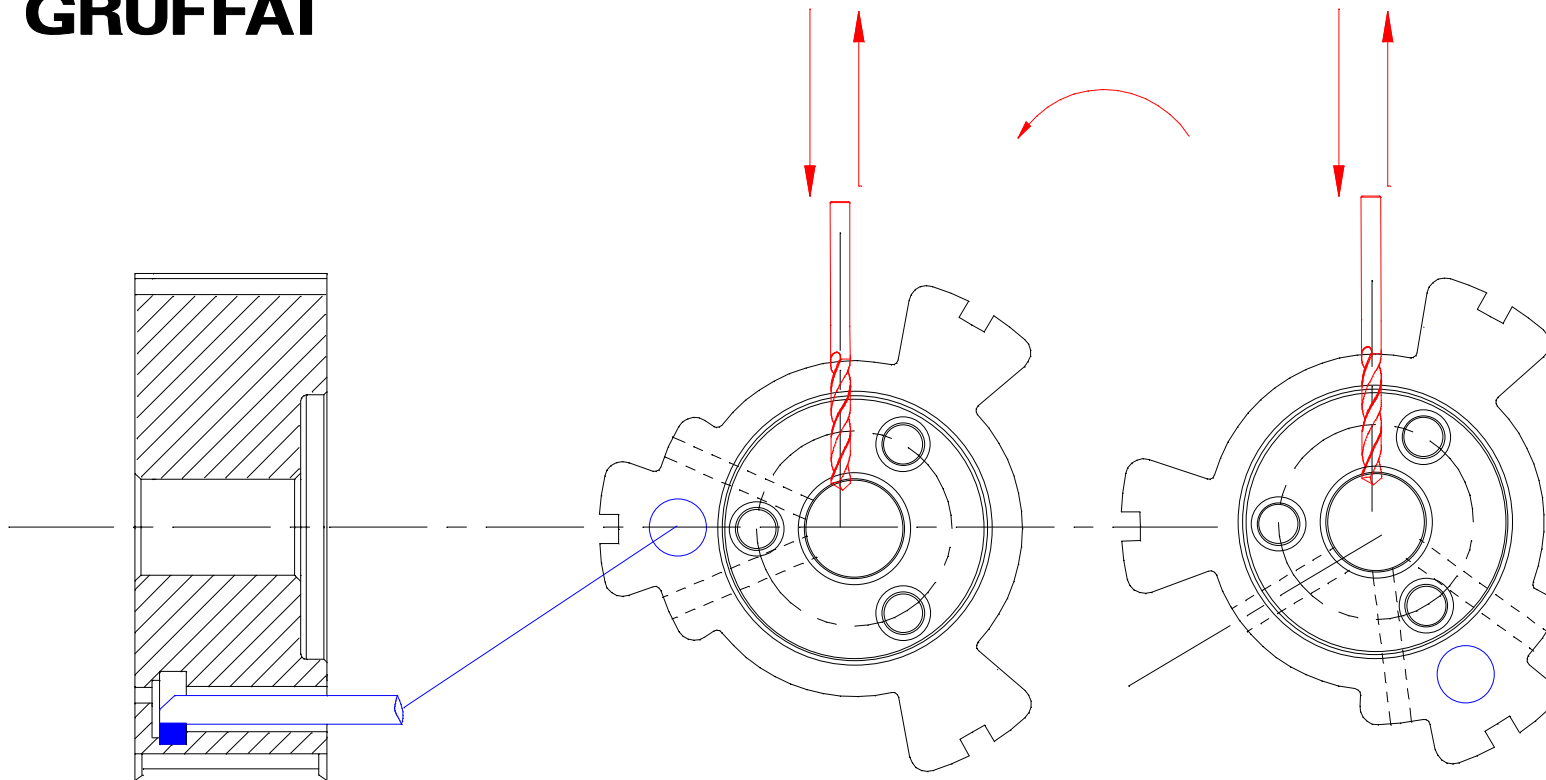
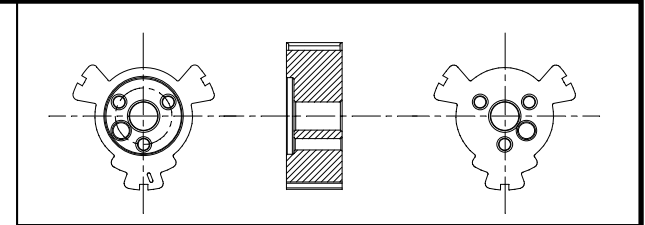

Station 7

Upper – Drill 2x $\text{Ø } 4.5$ # 48, 50 (V. Driven Spindle)

Lower – Recess $\text{Ø } 13$ # (H. Driven recessing Unit)

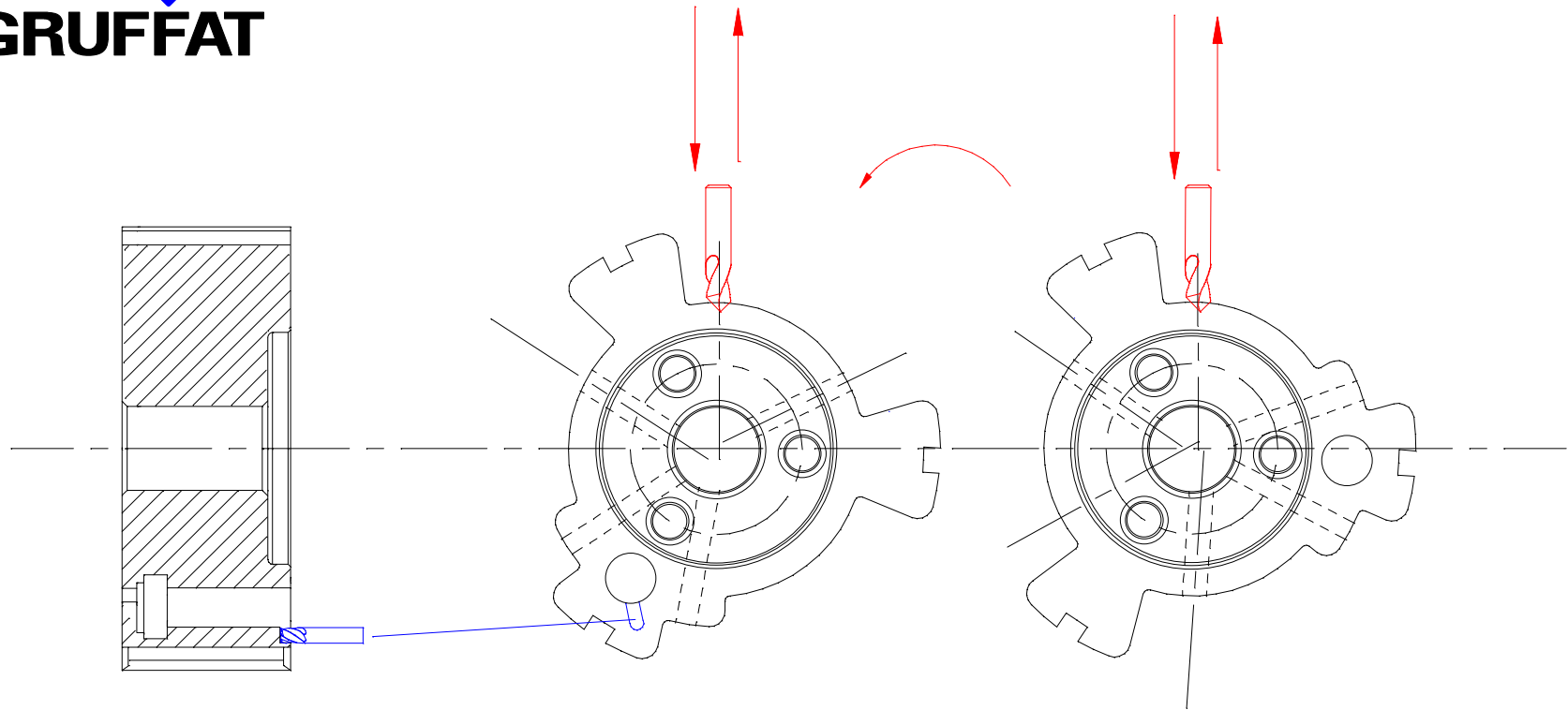
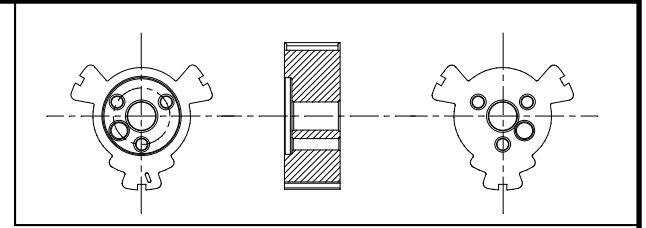

Station 8

Upper – Center Drill 2x # 60,61 (V. Driven Spindle)

Lower – Mill 2mm Slot # 66 (H. Driven Spindle)

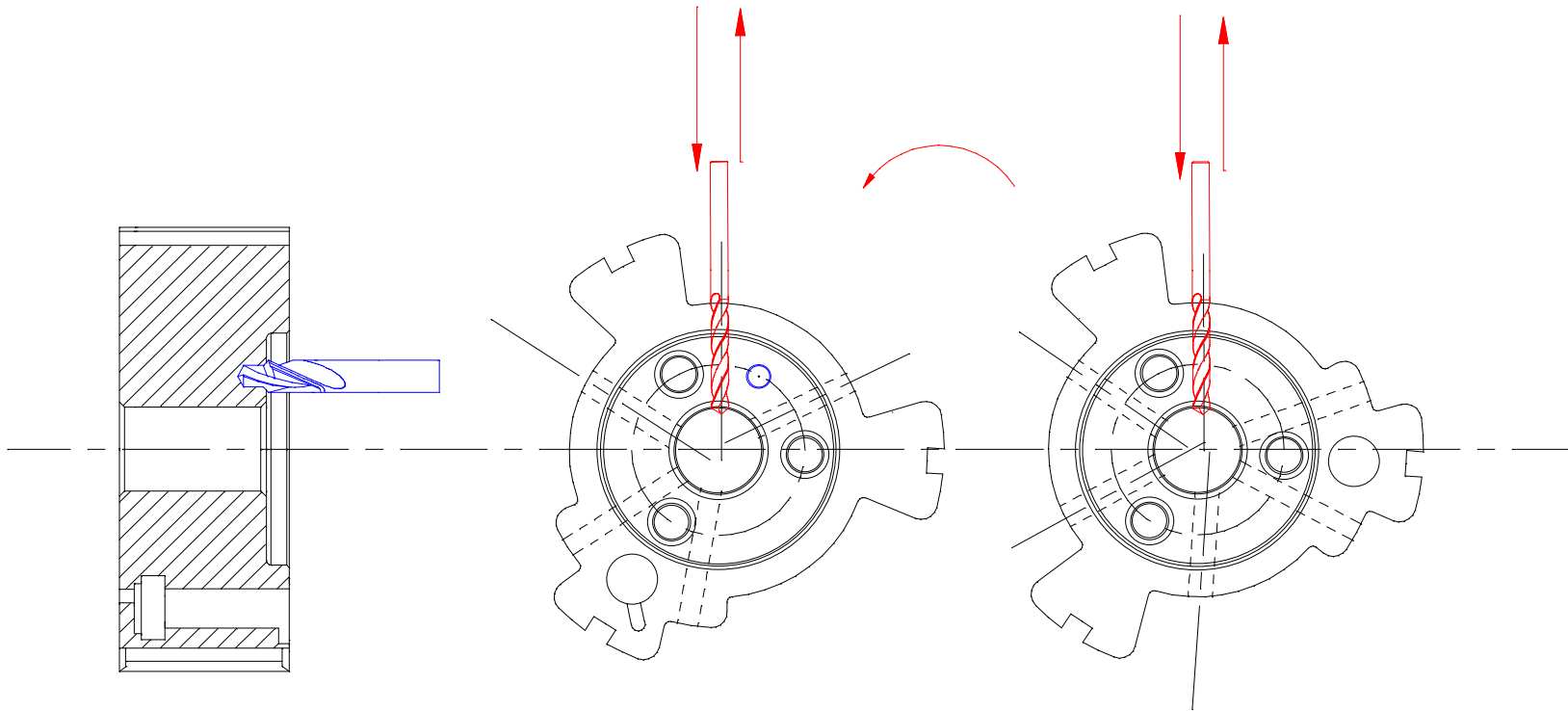
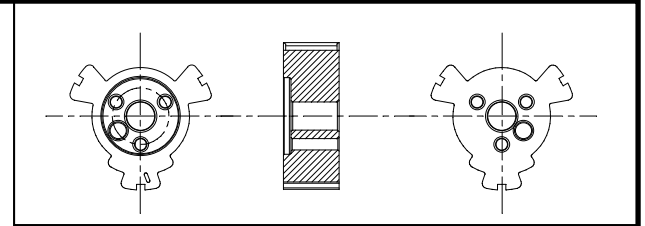

Station 9

Upper – Drill 2x Ø 4.5 #60,61 (V. Driven Spindle)

Lower – Drill/Chamfer Ø 4.5 # 75 (H. Driven Spindle)

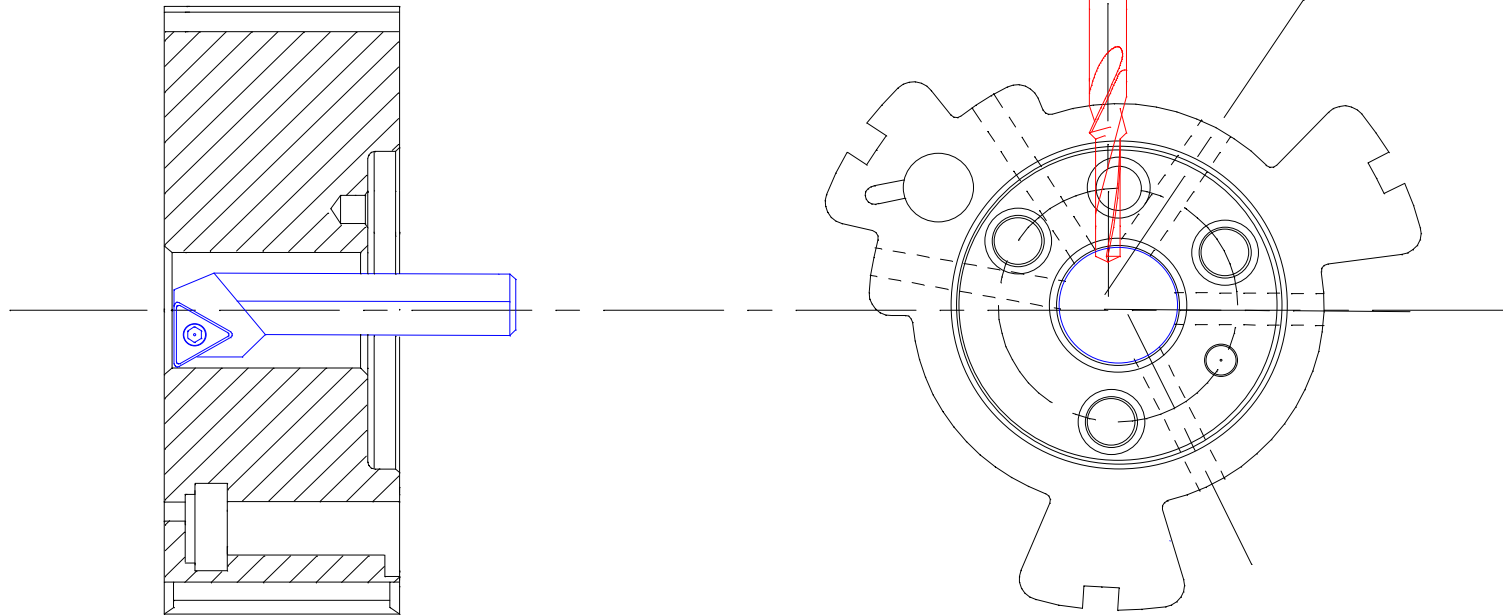
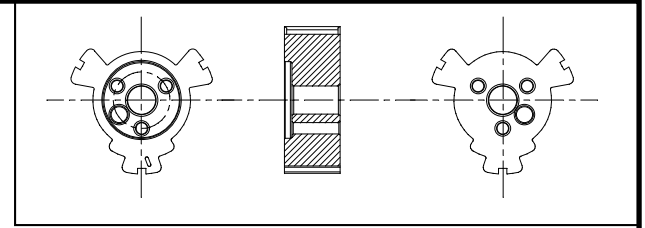

Station 10

Upper – Stepdrill # 98/100 (V. Driven Spindle)

Lower – Turn $\text{Ø}16.17$ # 81

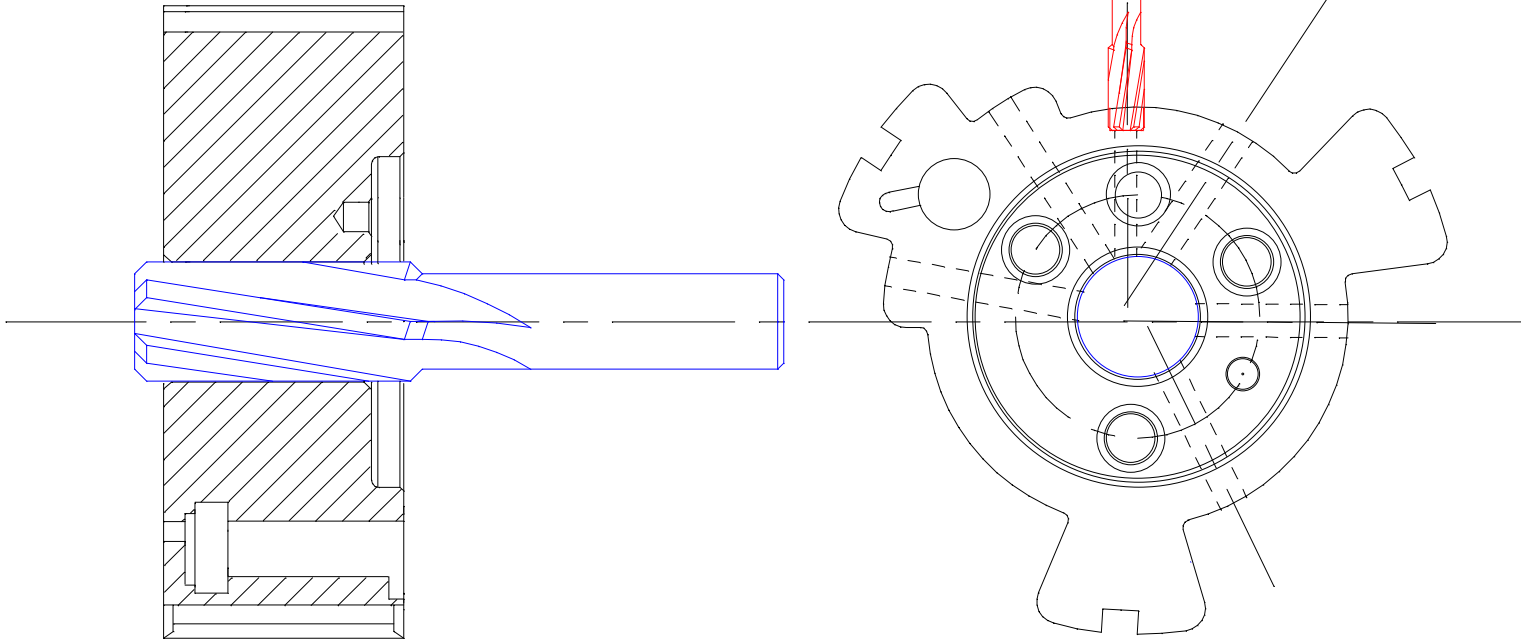
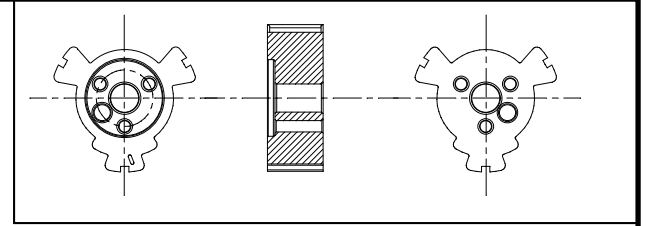

Station 11

Upper – Ream Step \varnothing 5.48 #100 (V. Driven Spindle)

Lower – Ream \varnothing 16.17 # 81

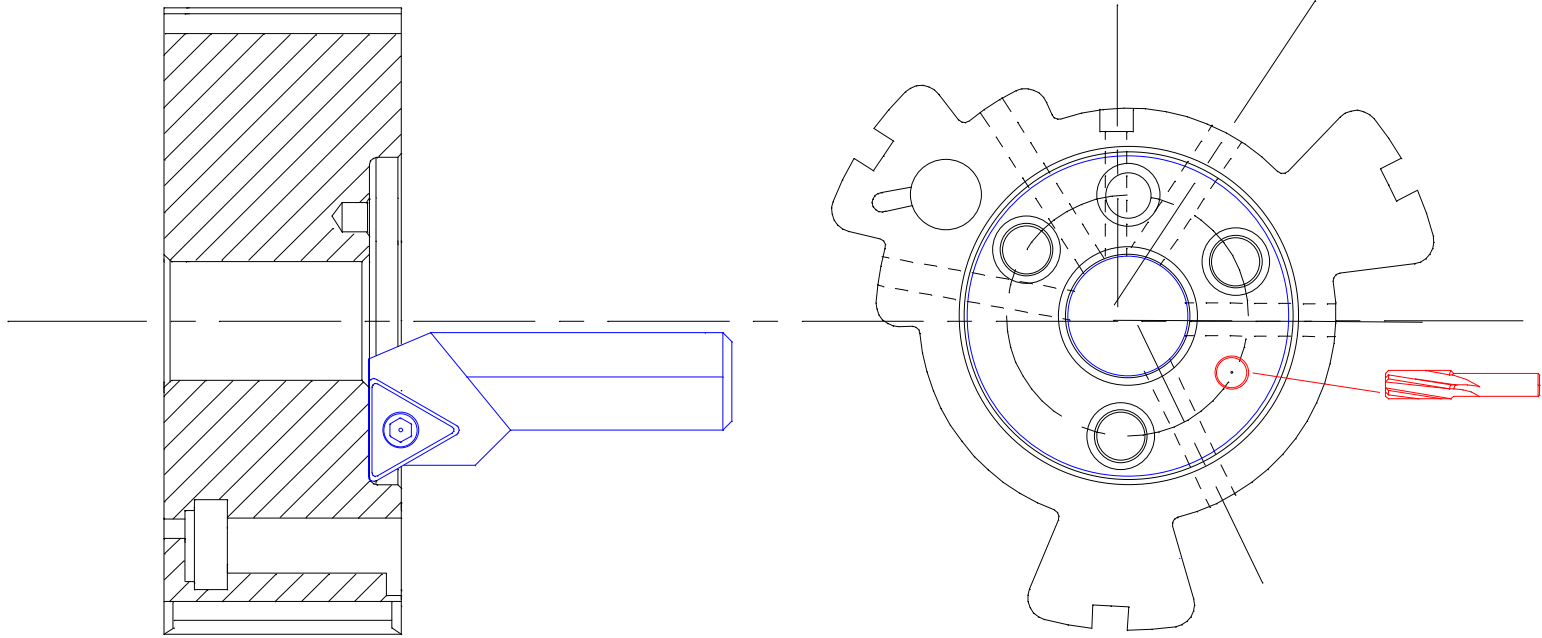
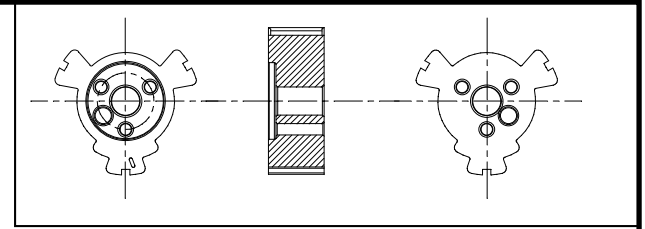

Station 12

Upper – Ream $\text{Ø } 4.67$ #75 (H. Driven Spindle)

Lower – Finish Turn Datum “A”

Operational Sequence Rotor

Est. Cycle time: 18.3 Seconds

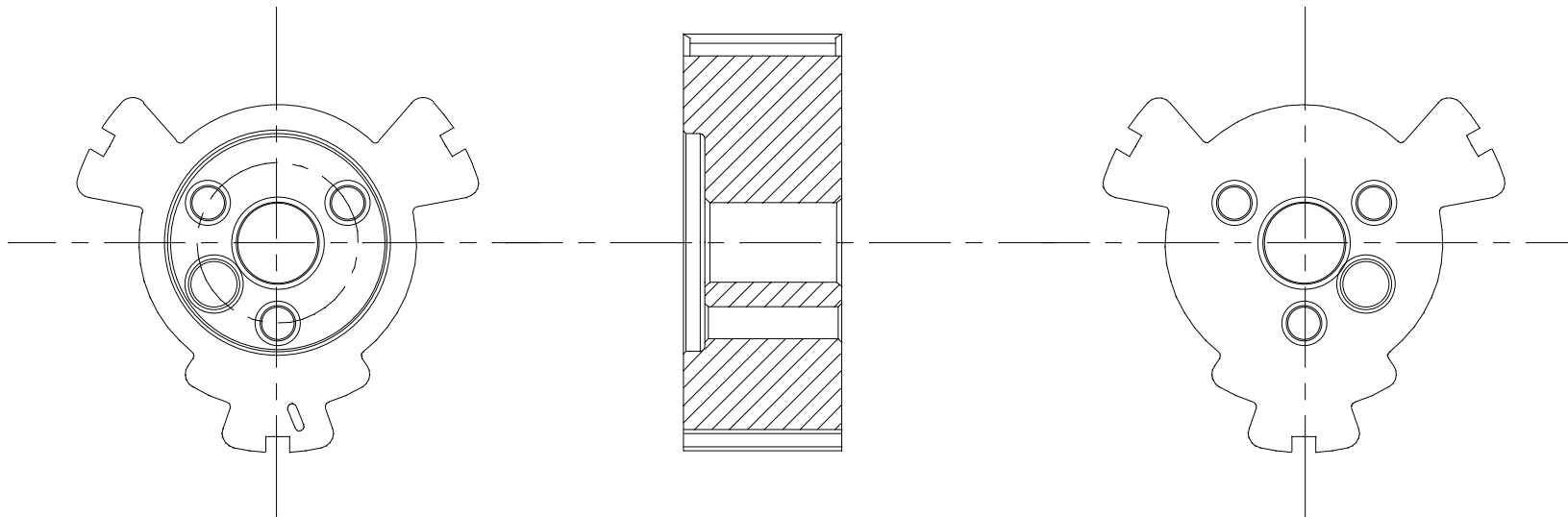

Operational Sequence Sprocket

Est. Cycle time: 16 Seconds

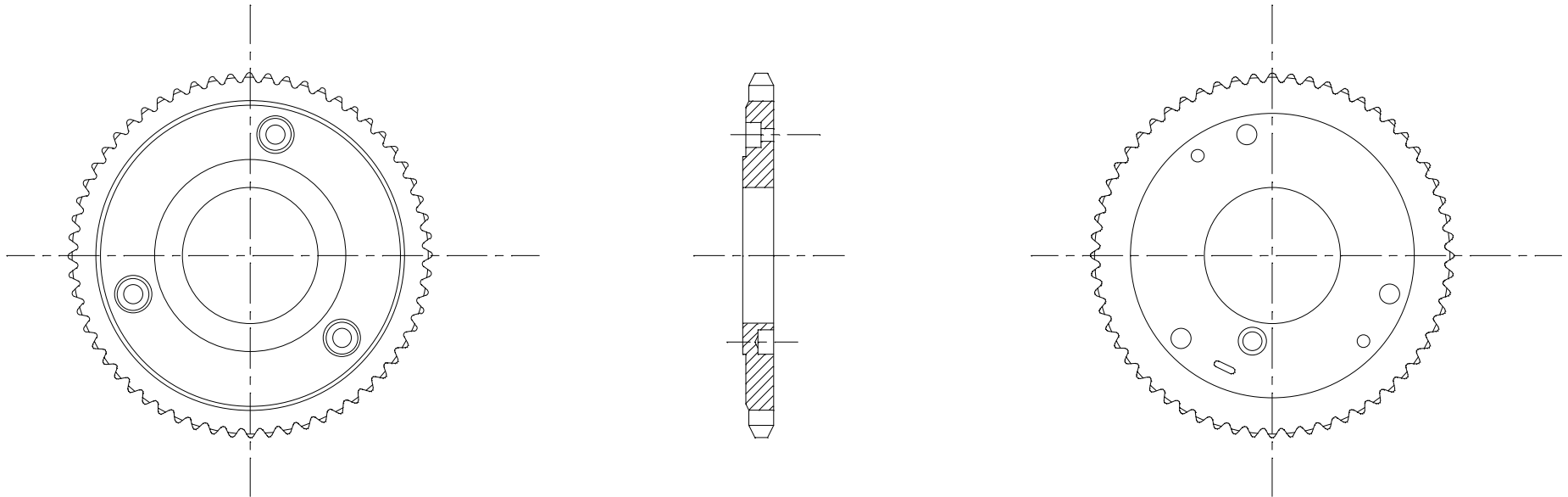

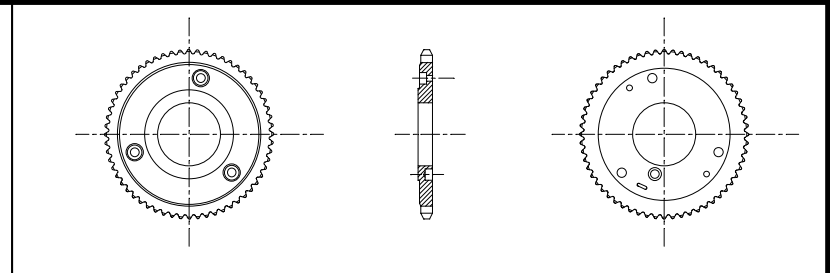

3 Jaw Self Centering
Hydraulic Chucks

Clamp Over Ball Dim on
Gear Tooth Form

Locate on Datum "A"

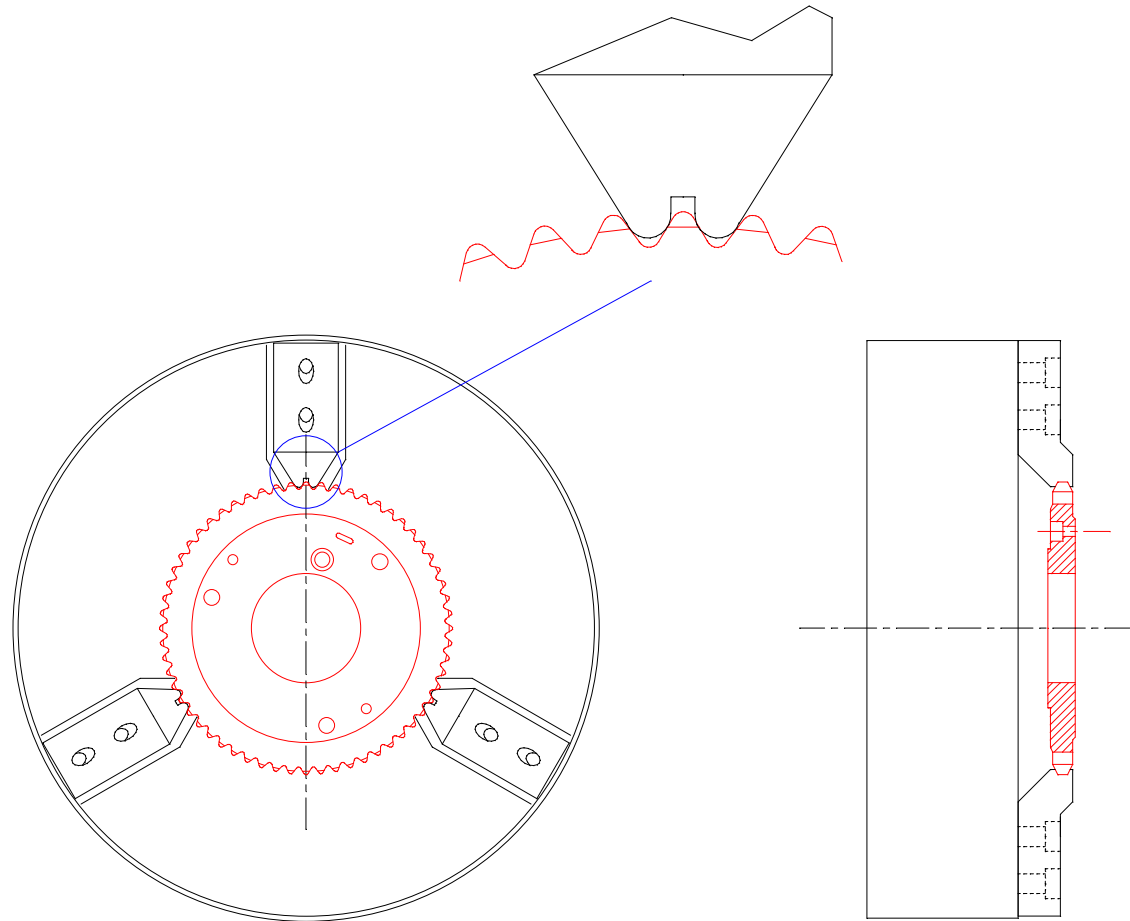

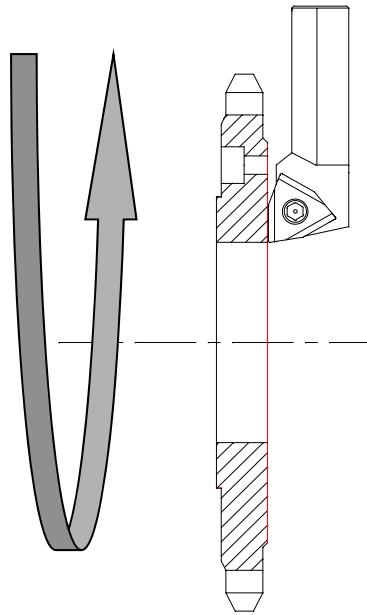
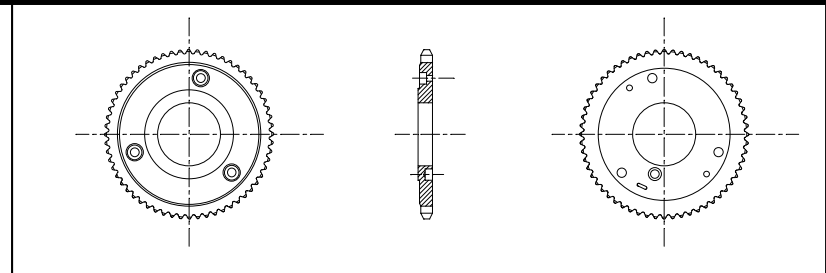

Station 2

Upper - Turn Face opposite Datum "A"

Lower - open

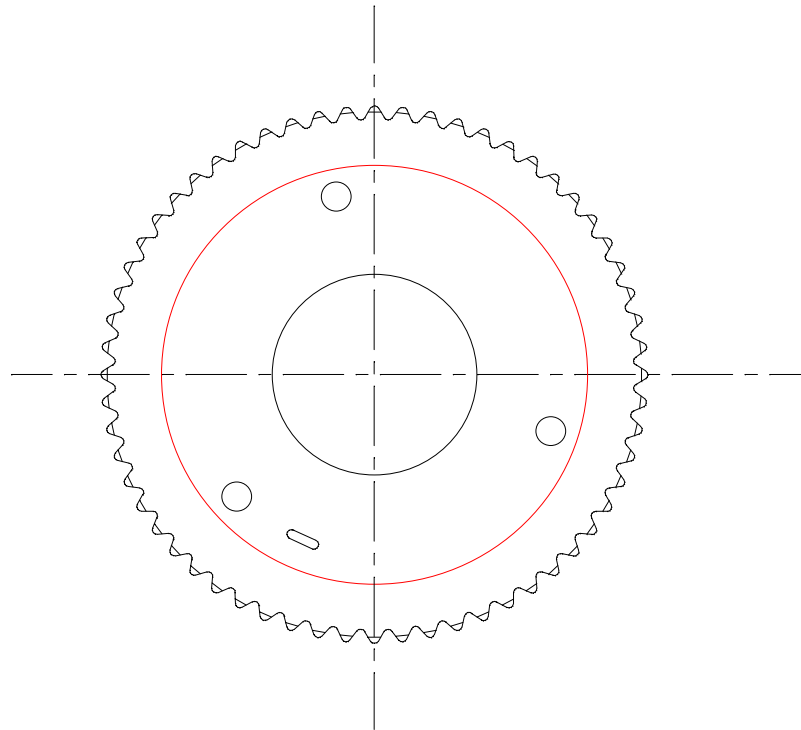

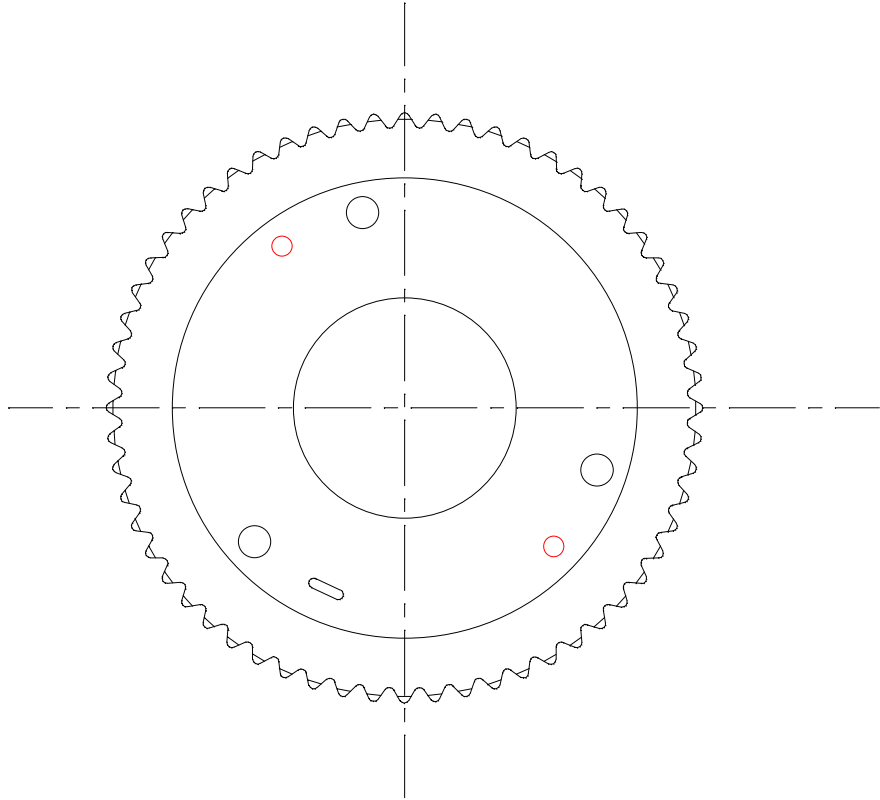
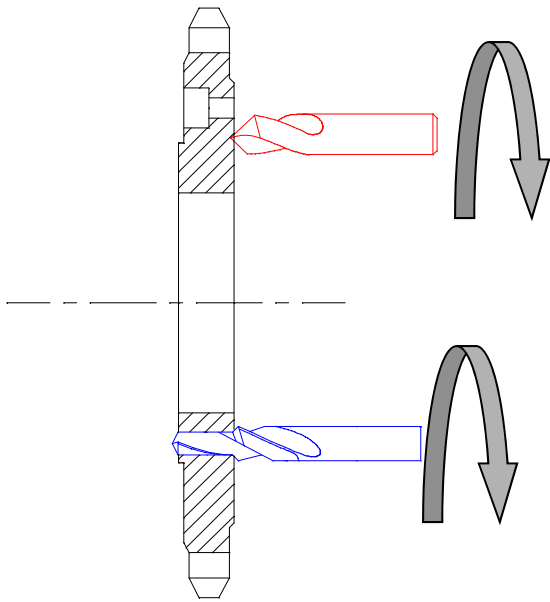
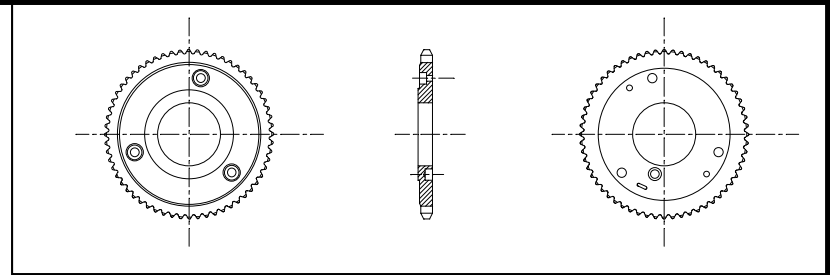

Station 3

Upper – Center Drill 2 X (H. Driven Spindle)

Lower – Drill $\text{\O} 3.9$ 2X (H. Driven Spindle)

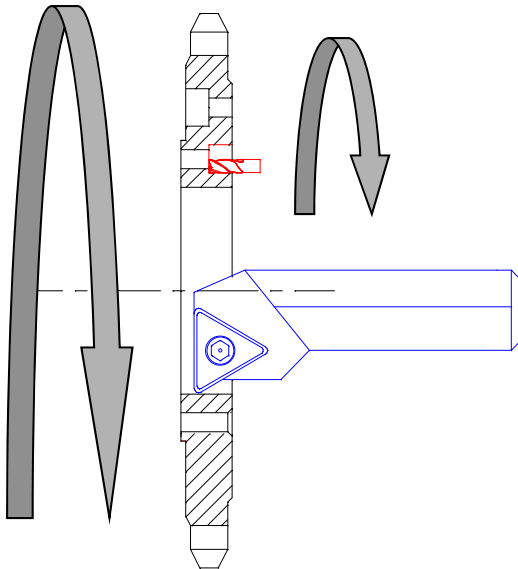
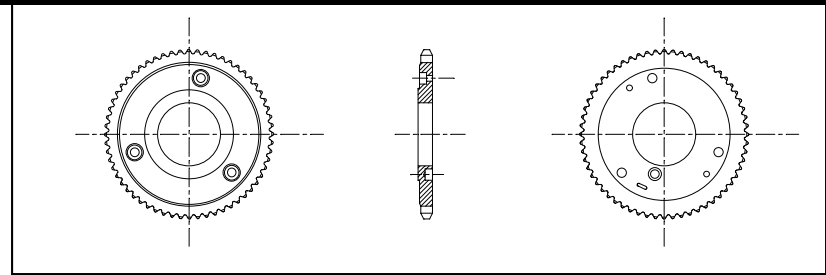

Station 4

Upper – End Mill $\text{Ø}4.06$ (H. Driven)

Lower – Turn $\text{Ø} 43.02$ and Chamfer

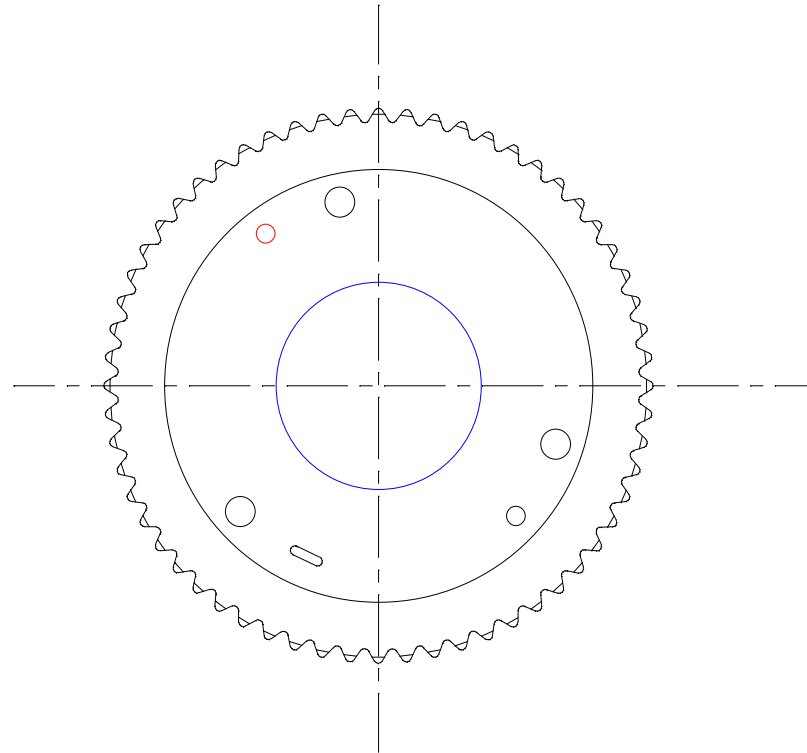

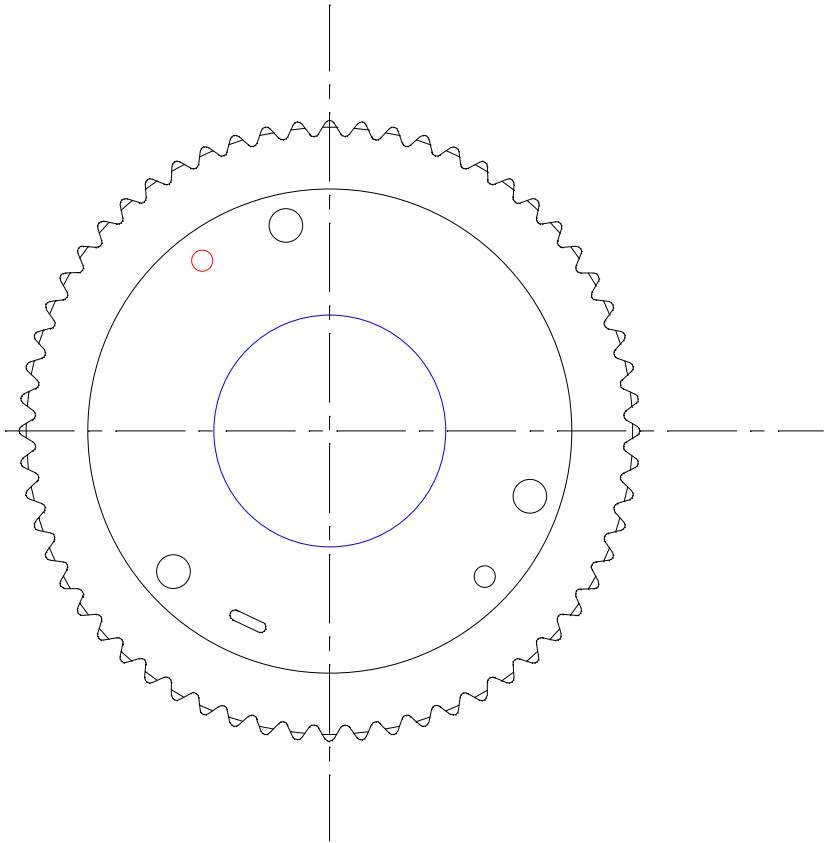
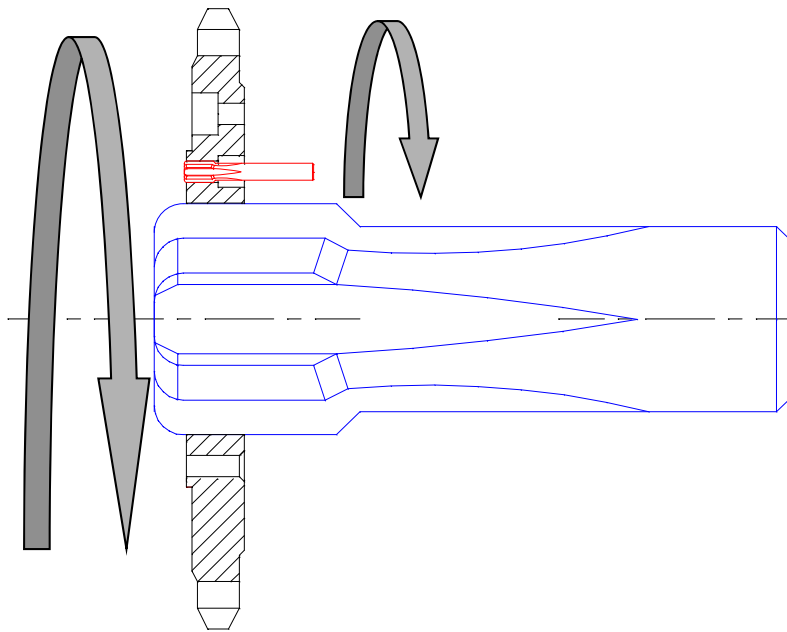
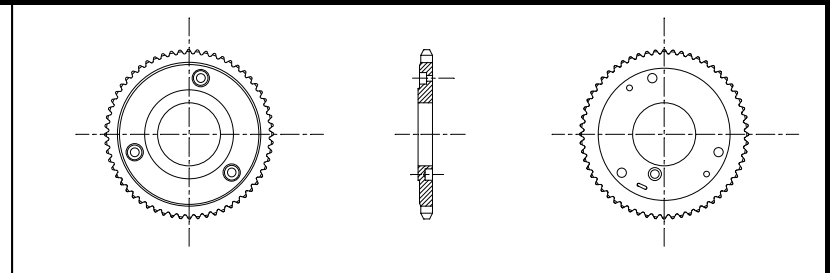

Station 5

Upper – Ream $\text{\O} 4.06$ (H. Driven Spindle)

Lower – Ream $\text{\O} 43.02$

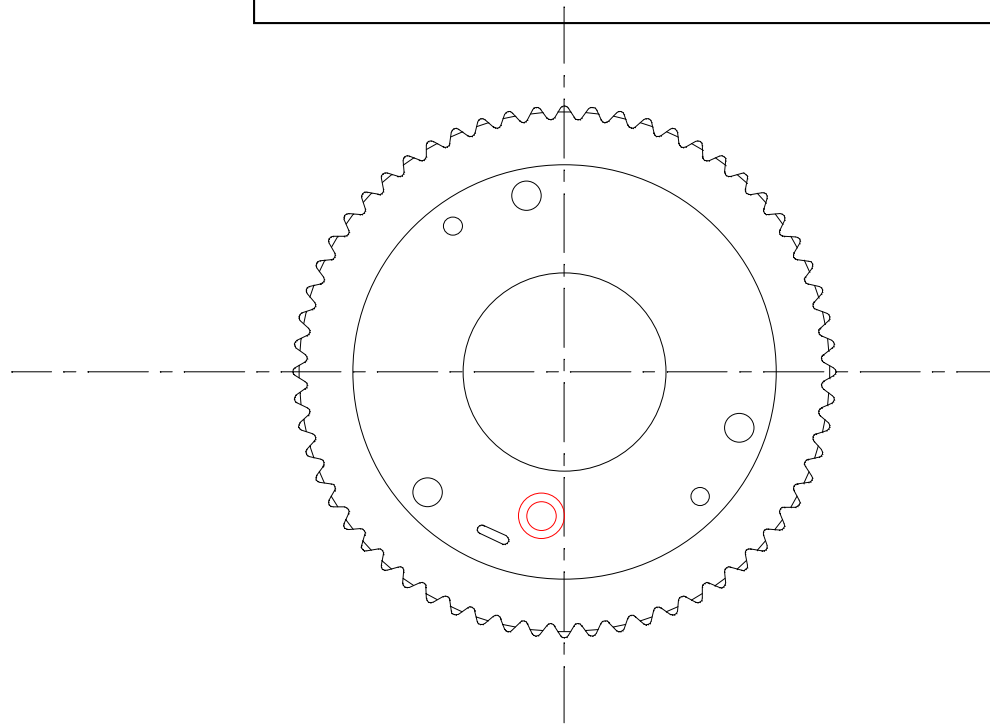
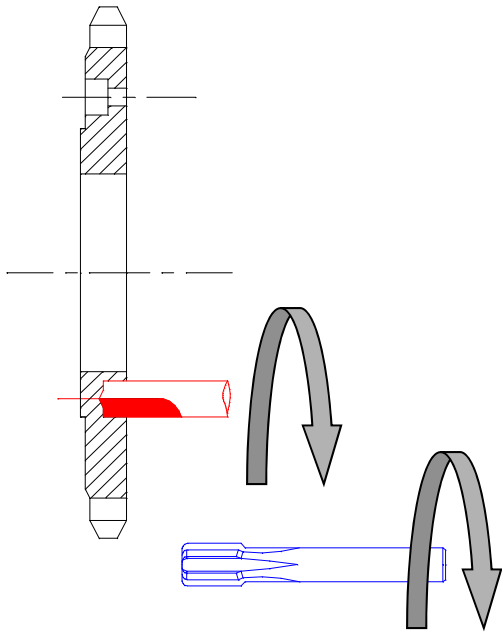
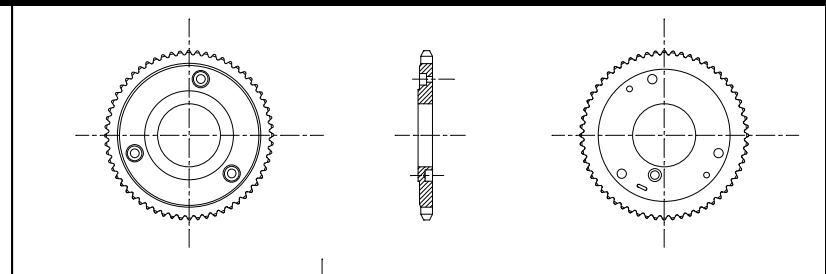

Station 6

Upper – Rough $\text{\O} 9.97$ -Special Tool (H. Driven Spindle)

Lower – Ream $\text{\O} 9.97$ (H Driven Spindle)

Operational Sequence Sprocket

Est. Cycle time: 16 Seconds

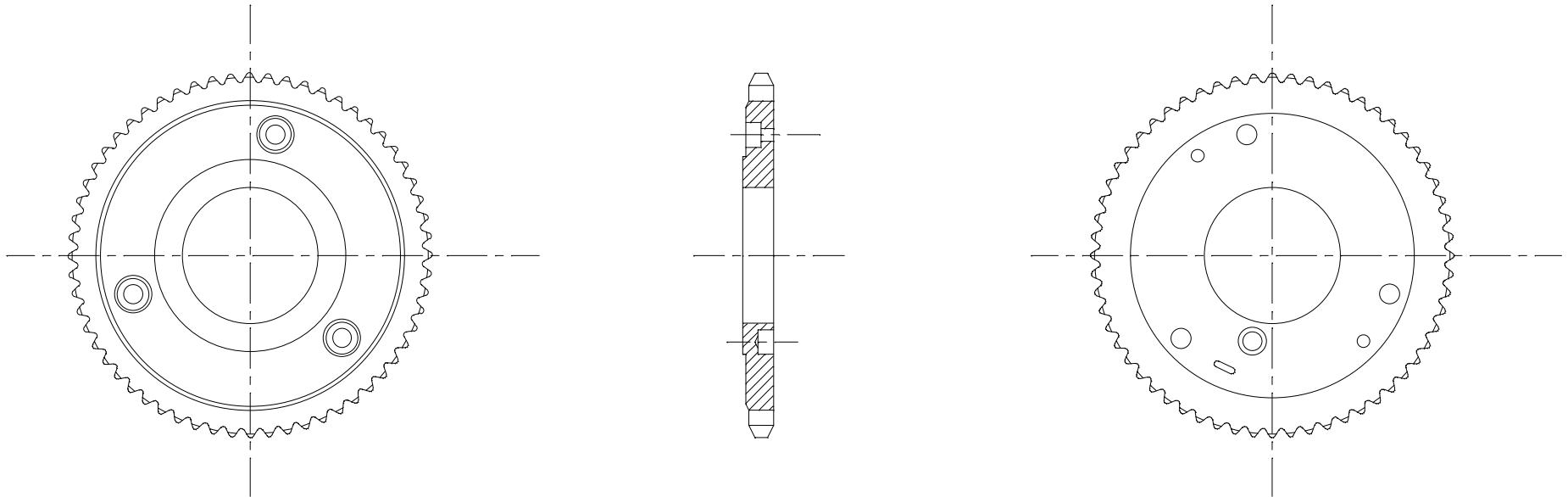



Transturn TT 312

Transturn TT 306

6 and 12 Station Precision
Transfer Machines



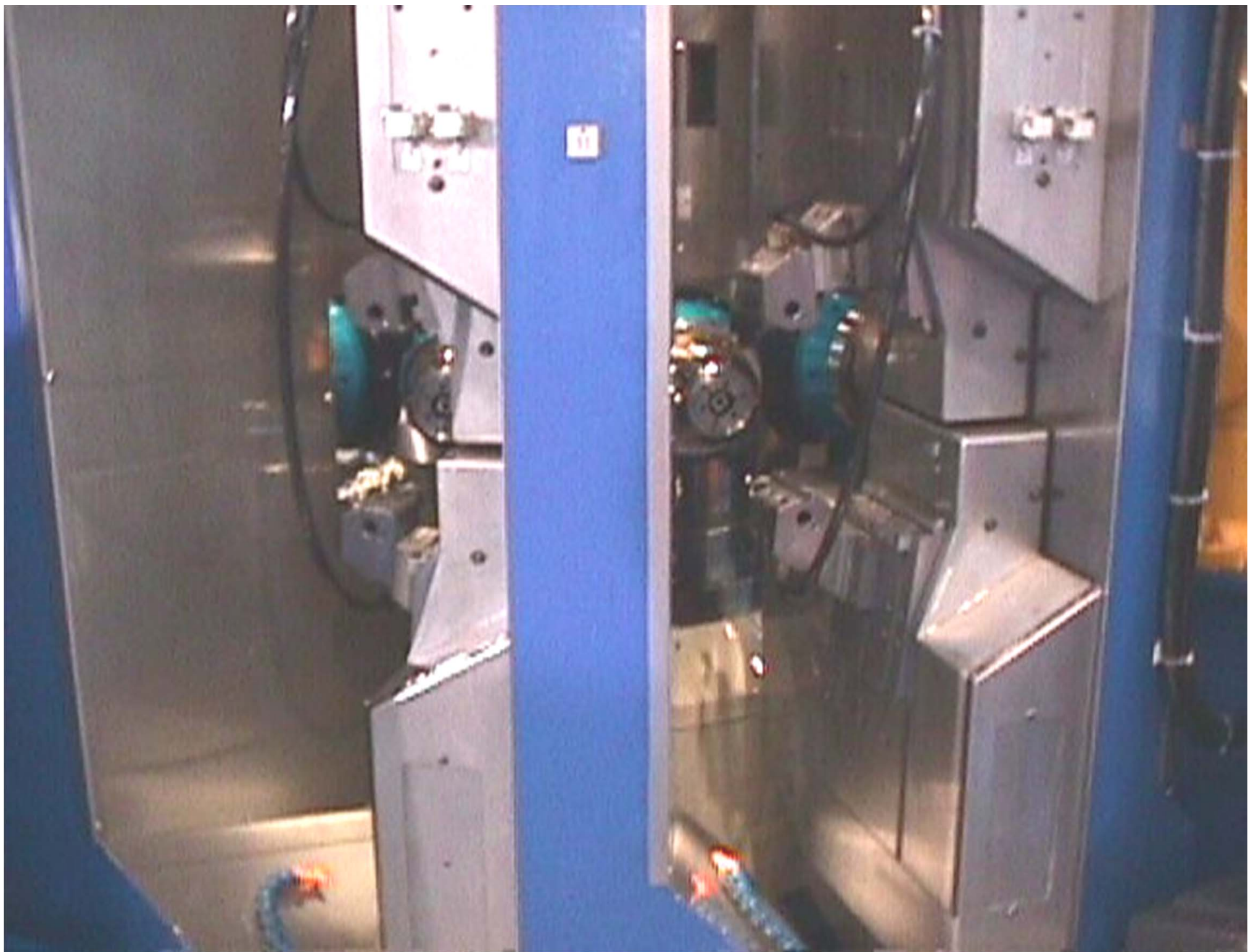

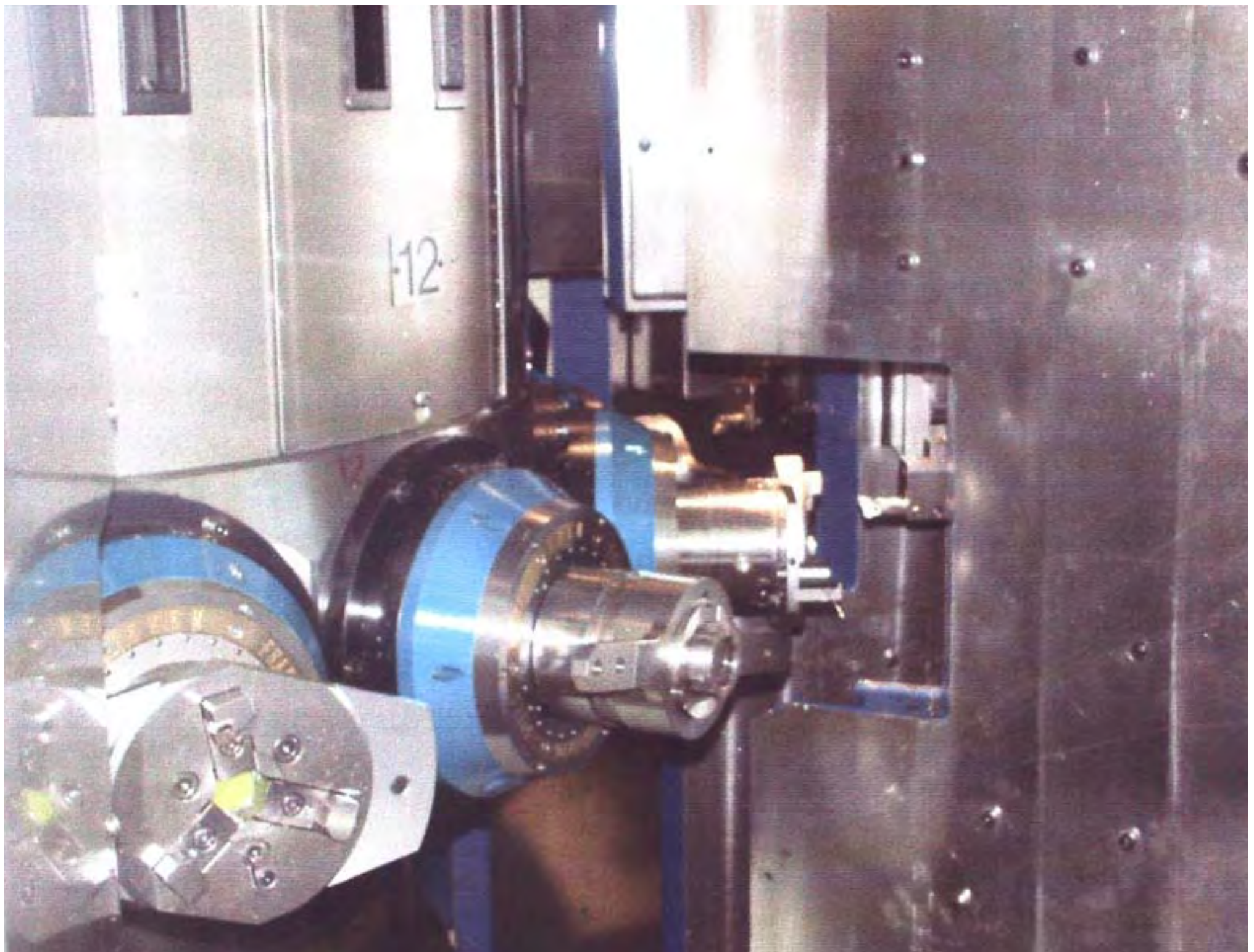



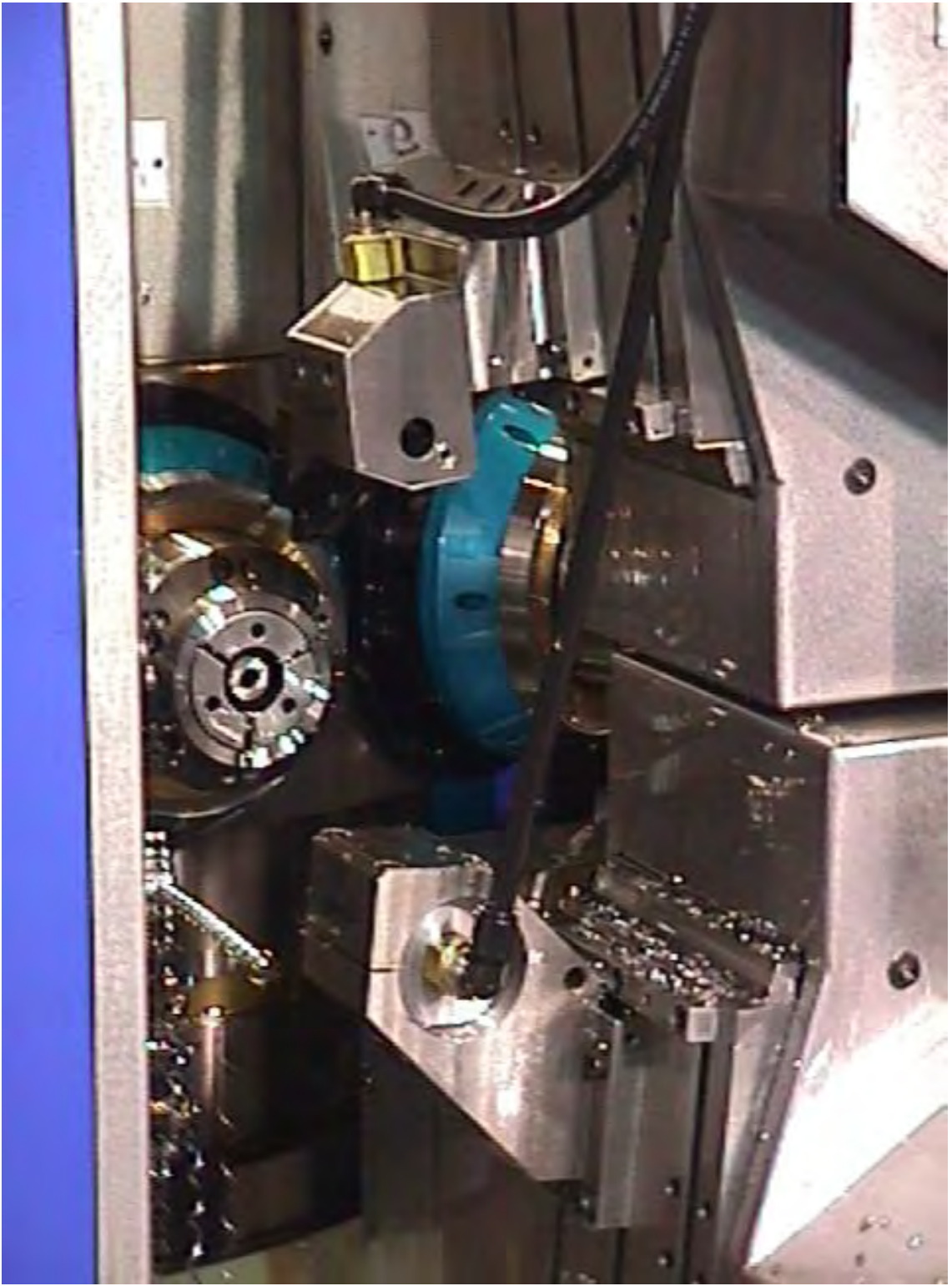

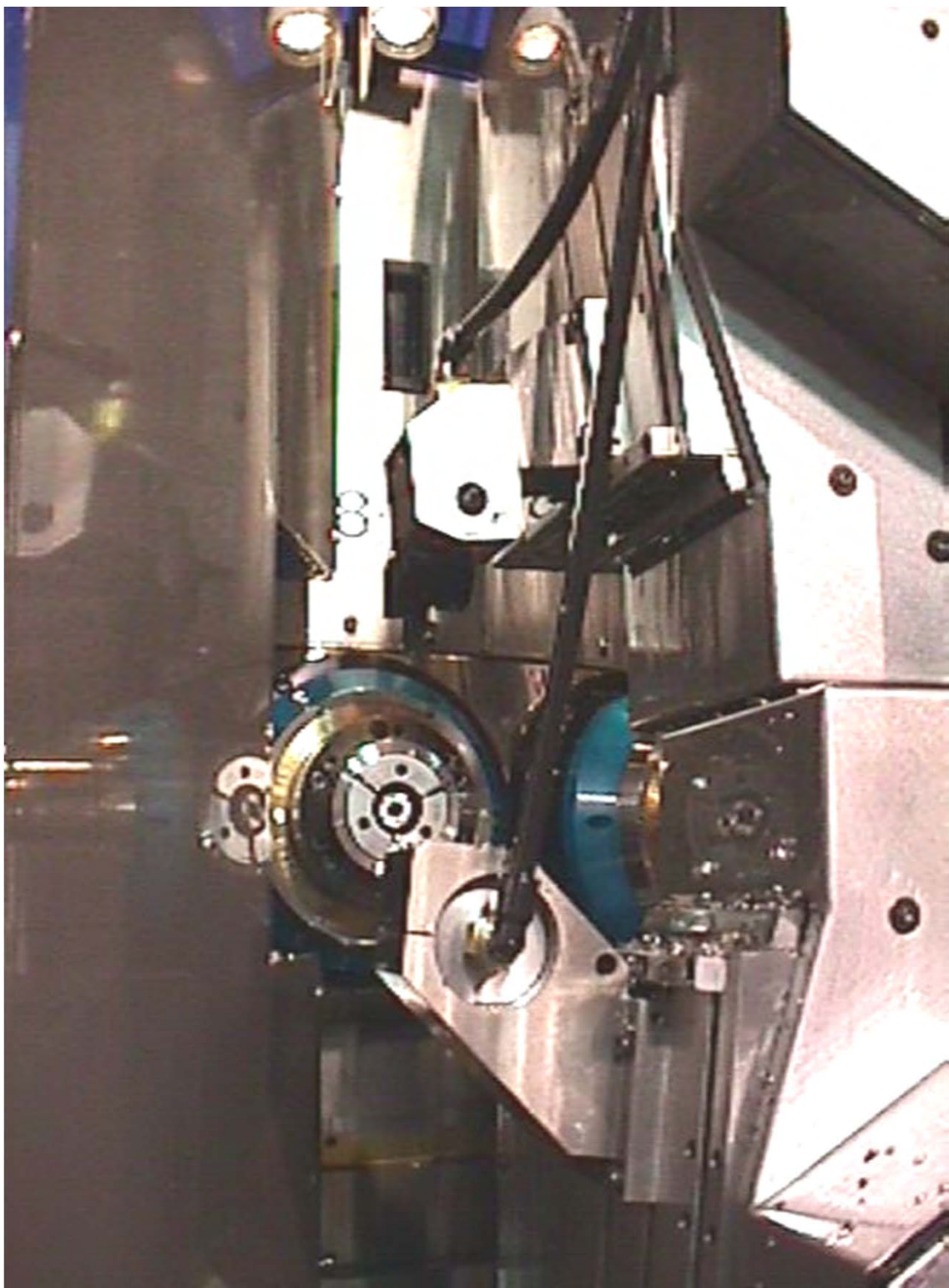









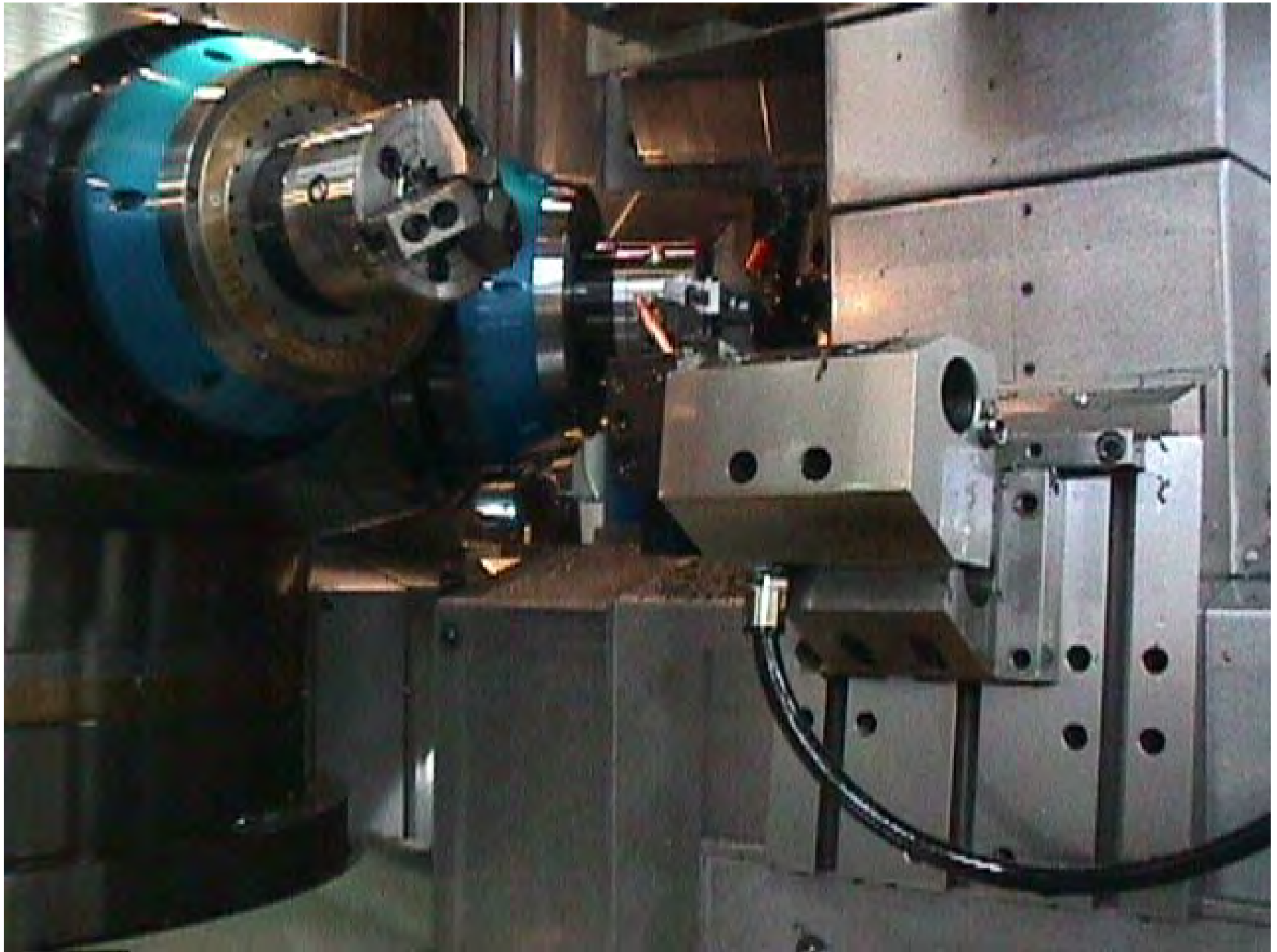







FEB 21 2003

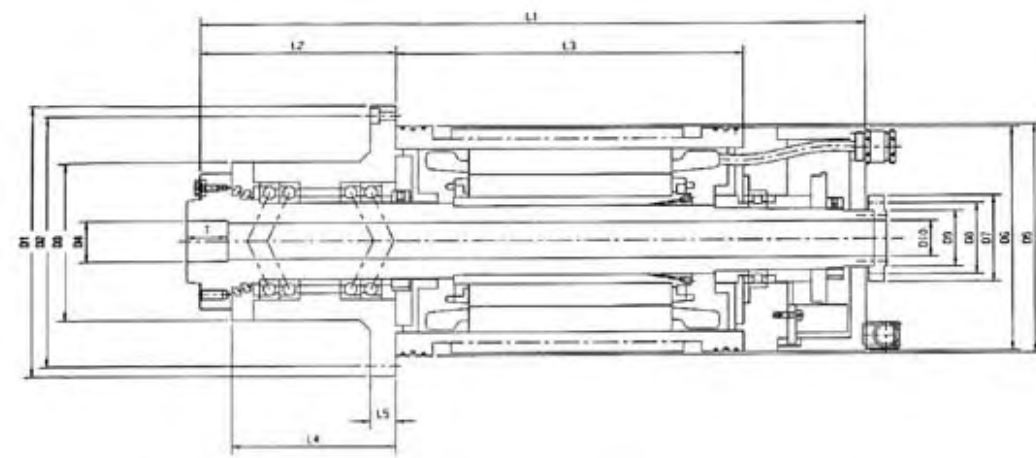



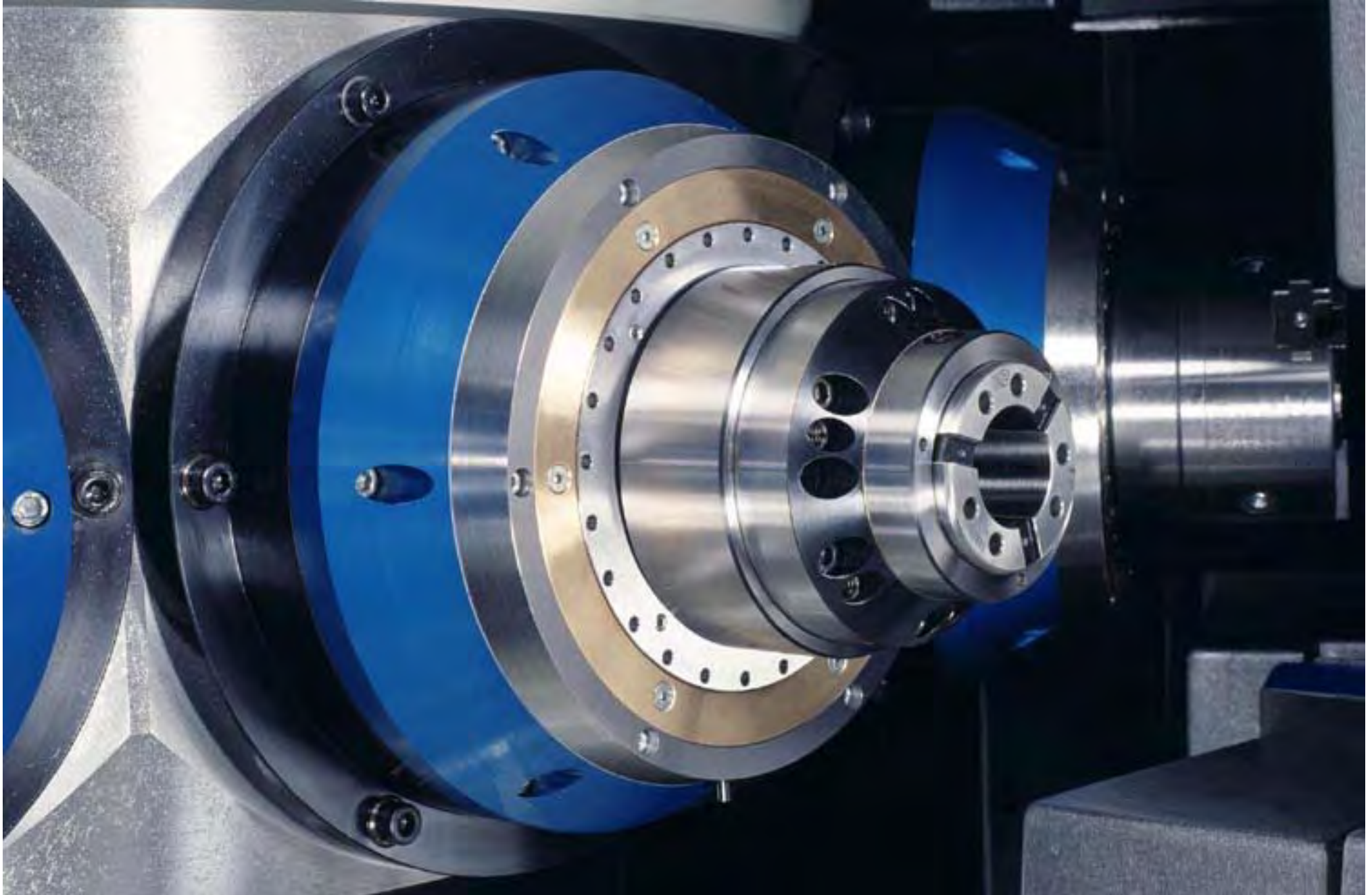

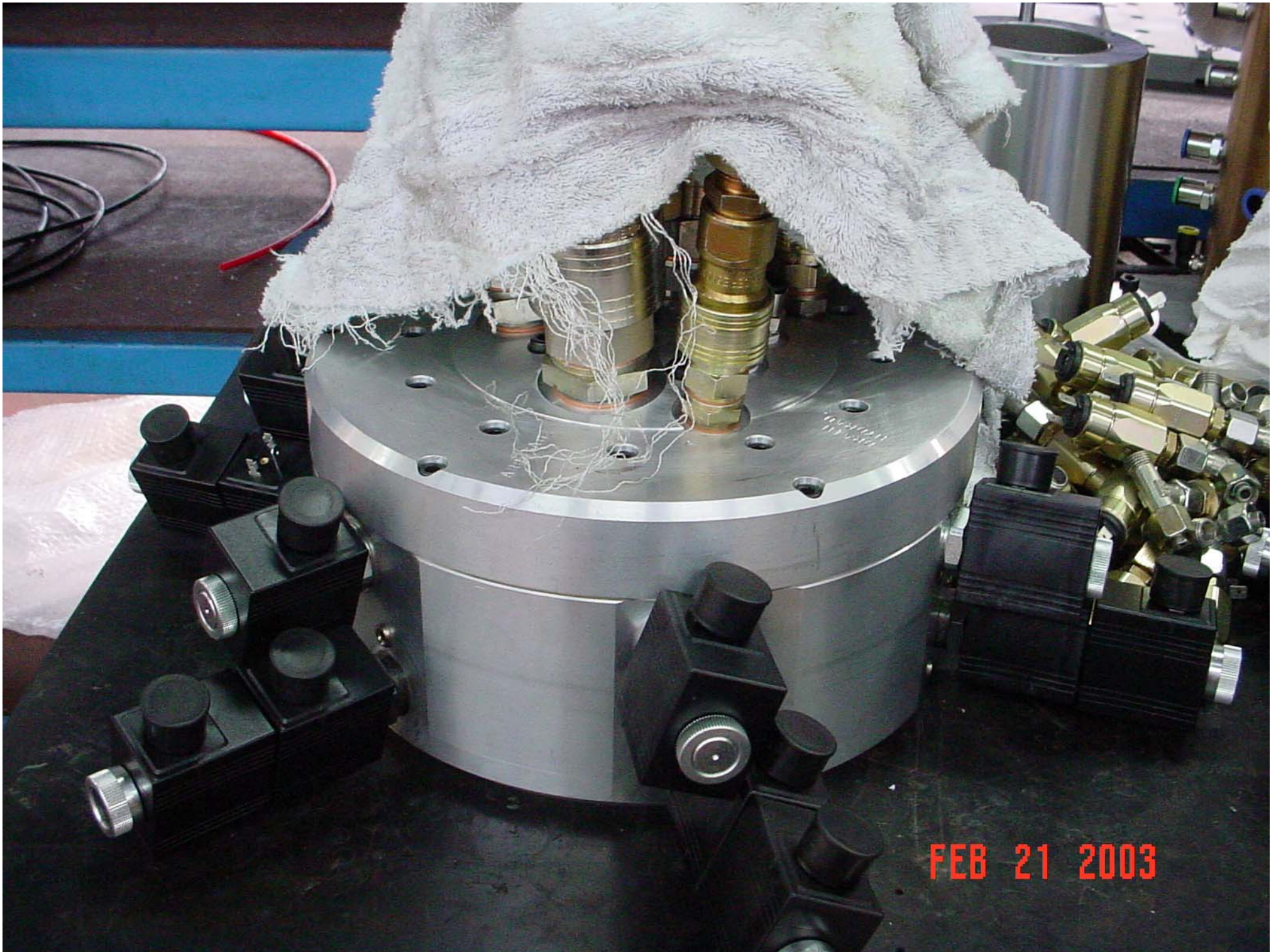

FEB 21 2003

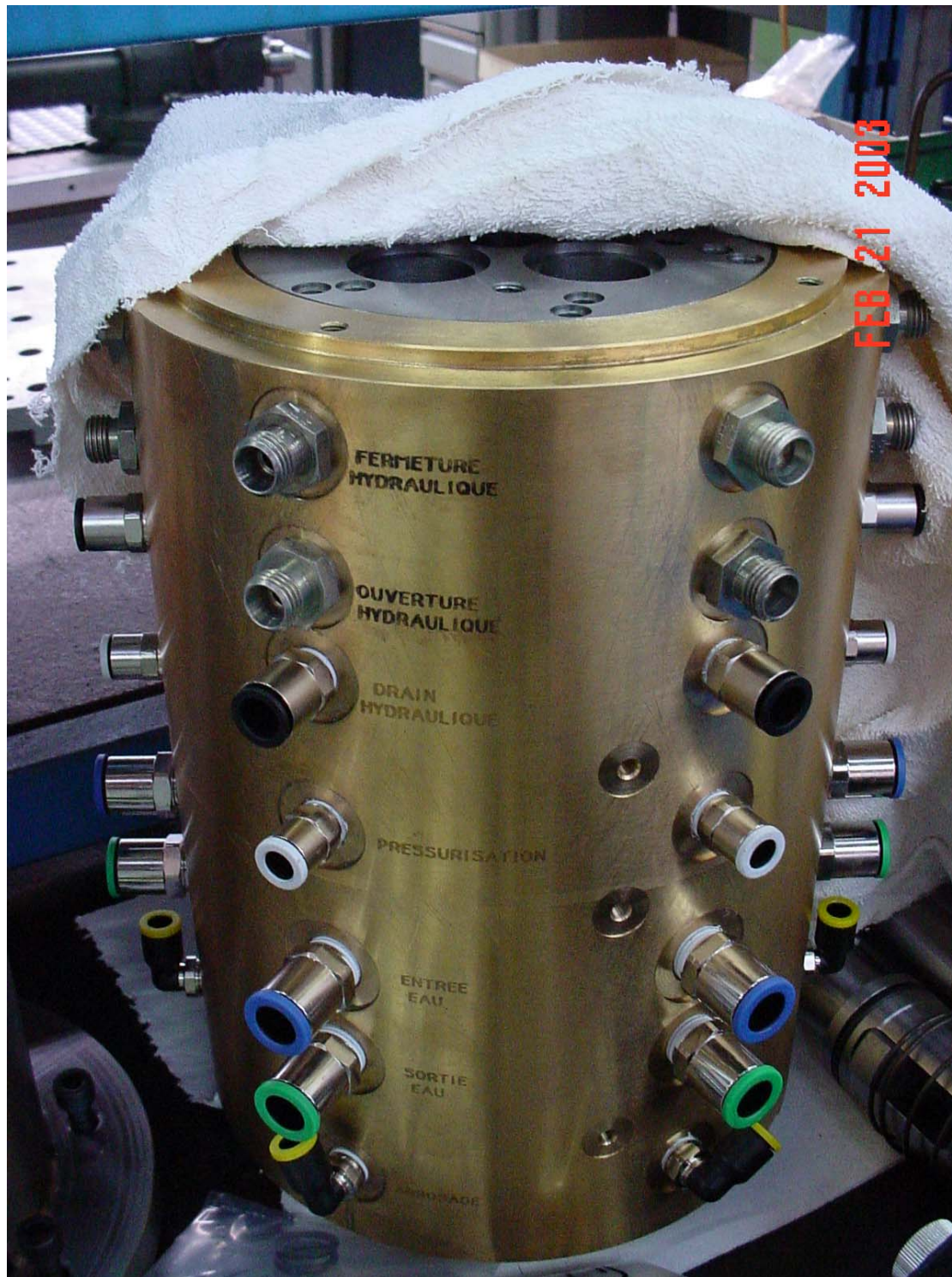

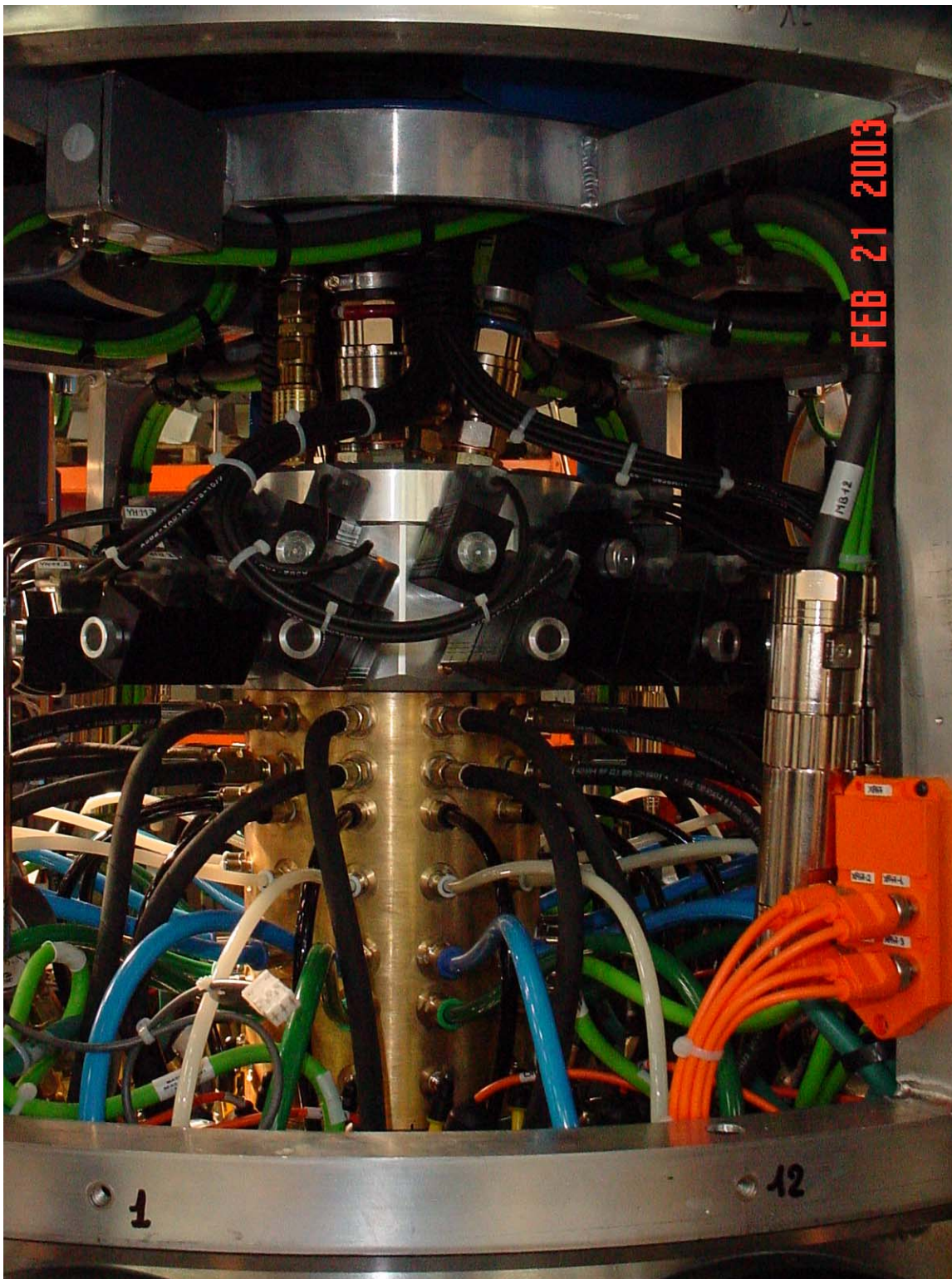



FEB 21 2003

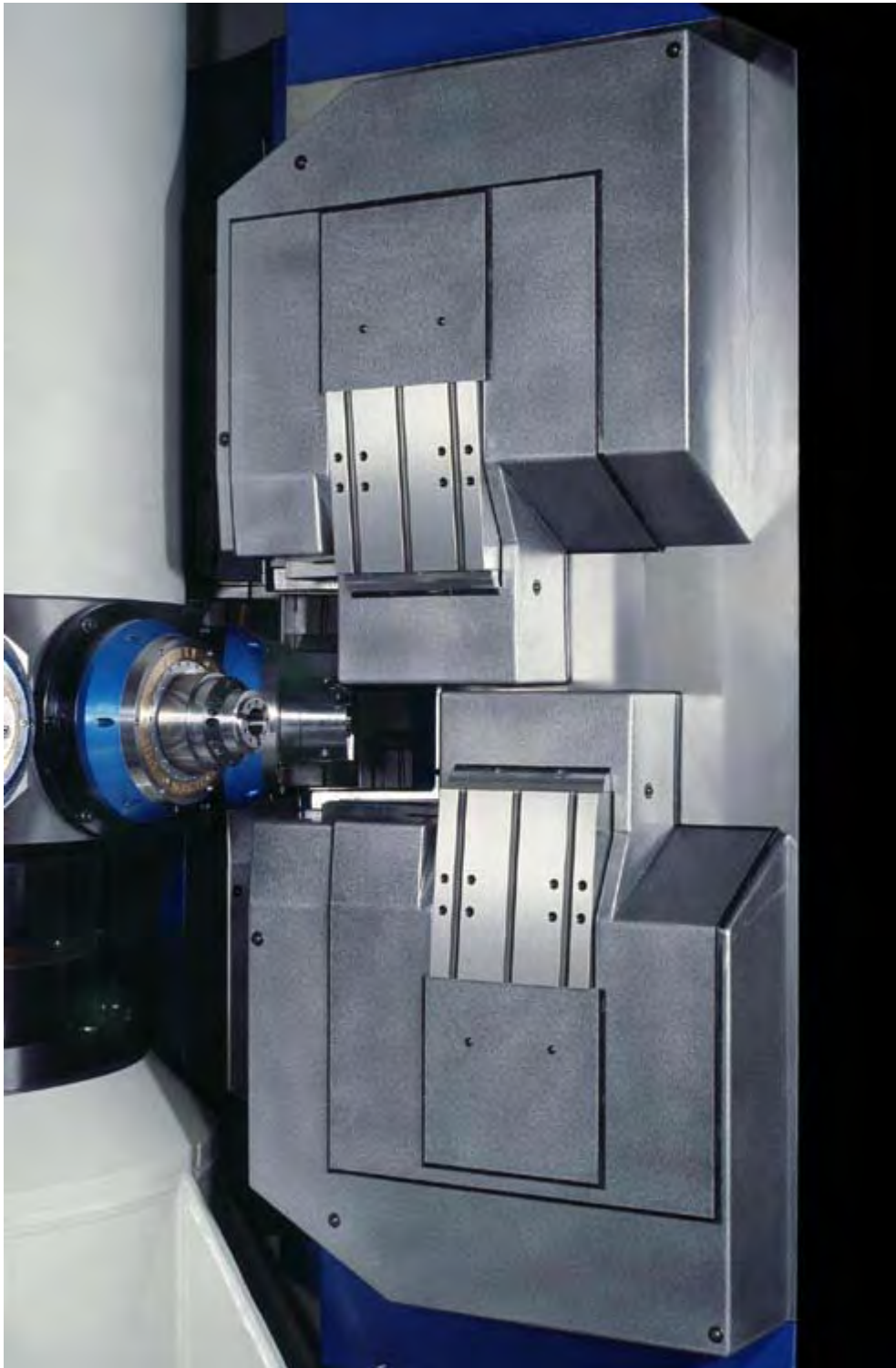

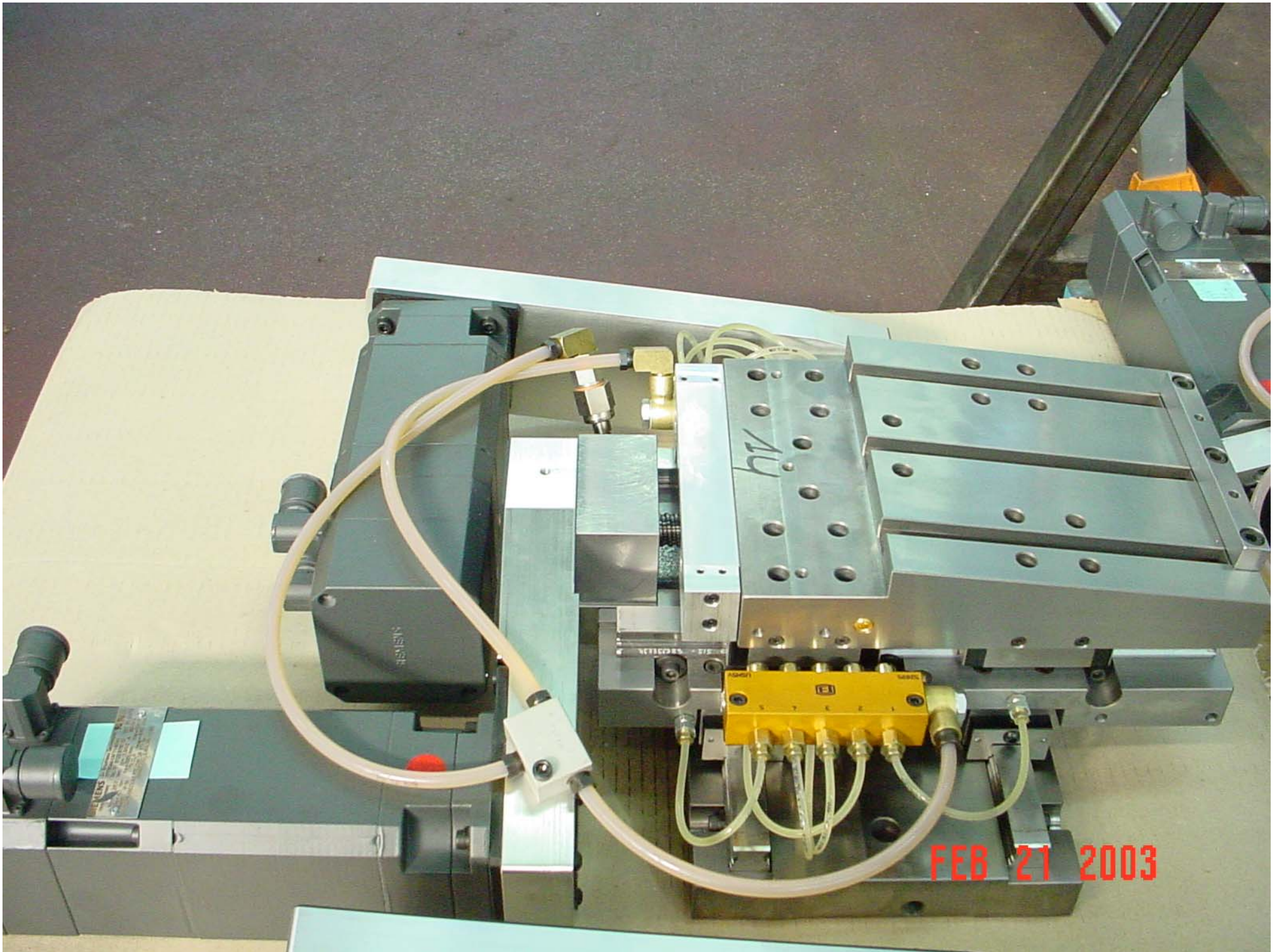

FEB 21 2003

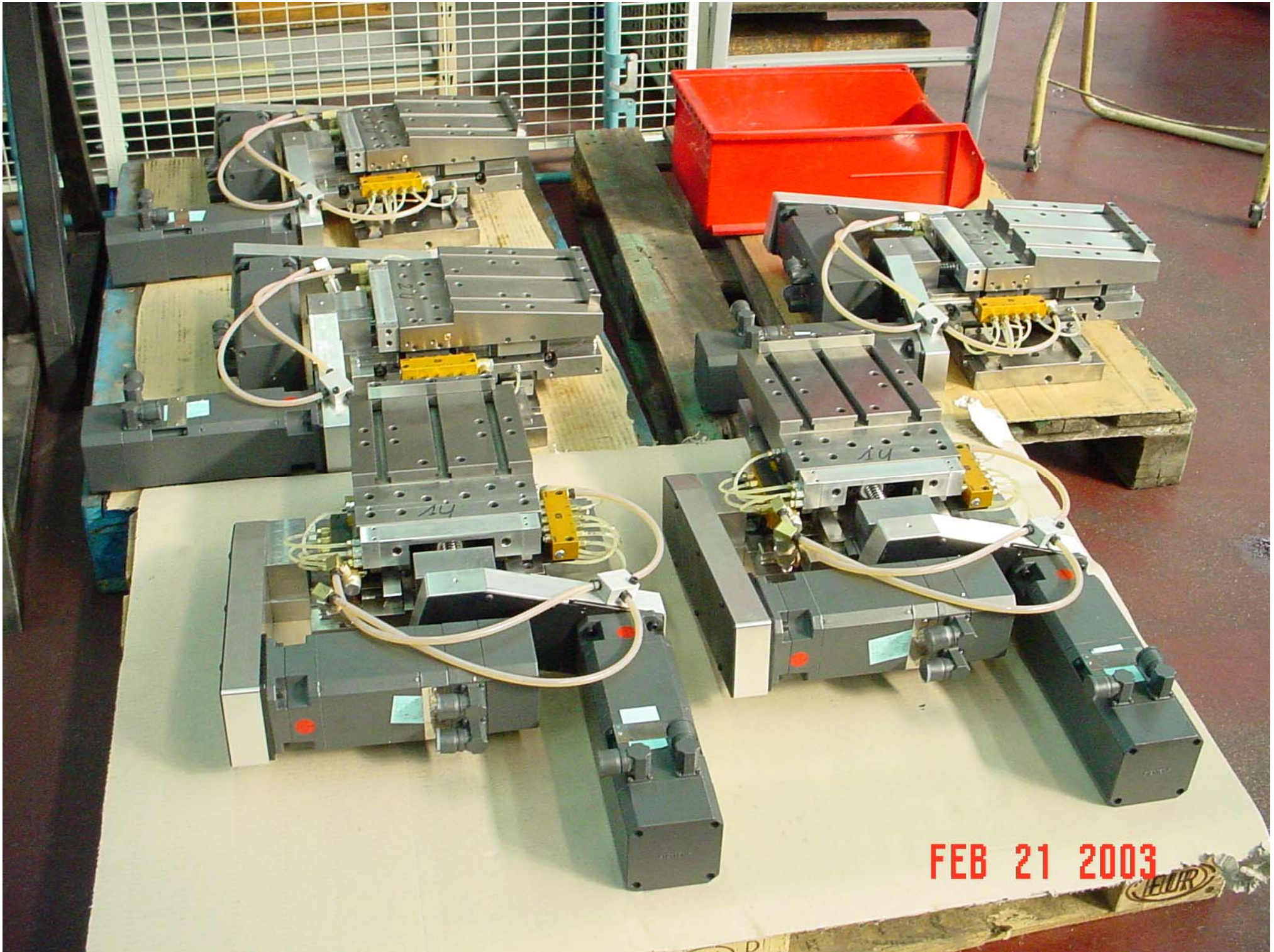

FEB 21 2003



