

The twin-spindle mill-turning center



MF twin 42 • MF twin 65

**GILDEMEISTER**

Drehmaschinen GmbH

# MF twin 42/65 - Two spindles for complete machining at the highest level.

■ It has always been important for GILDEMEISTER to develop lathes that safeguard and further enhance the competitive edge of our customers. This is only possible through close contact with our customers.

The analysis of market demands and the assessment of future developments with our customers continue to be the recipe for success for GILDEMEISTER machines.

Due to the most diverse customer requirements, technical solutions must, in future, be first more individually tailored to the customer and secondly must remain affordable. The new MF twin 42/65 is a two-spindle mill-turning center that provides a maximum of flexibility and also raises the possibilities for complete machining to a new level through its concept and performance characteristics.

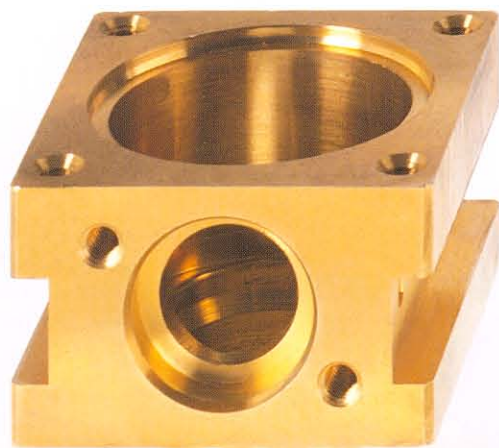



Two-spindle -



# 4-axis automatic production lathe for complex bar and chuck machining.

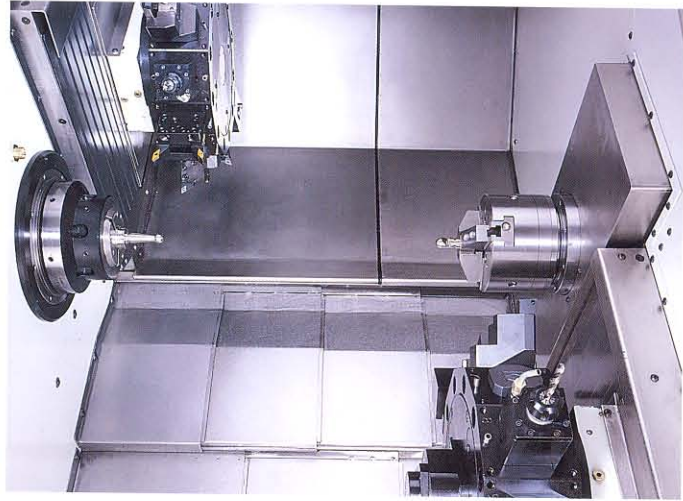

Parallel machining on the main and counter-spindle through slide synchronisation.

■ The MF twin 42/65 comes into its own especially where demanding drilling and milling work is required.

The GILDEMEISTER two-spindle automatic lathe MF twin 42/65 completely machines bar and

MF twin 42 main spindle is 19 hp and 16 hp for the counter spindle or even 28 hp for the MF twin 65 with a bar capacity of 2<sup>9</sup>/<sub>16</sub> inch at the main spindle, C-axis on both spindles, two 12 station VDI 30 turrets, usable on the main and counterspindle, driven tools on both turrets, chip conveyor.

For extended complete machining, in the fully equipped version, the MF twin 42/65 has a Y-axis (+ 1.6 inch) in the upper turret and thus permits milling and eccentric machining operations.

chucking parts. Even the basic version, the MF twin 42/65, is equipped for complete machining: The drive power for the



The CNC bar-type automatic lathe MF twin 65 is characterized by high flexibility, precision, reliability and economical production of most complex parts.

# Powerful components

attuned to your requirements.

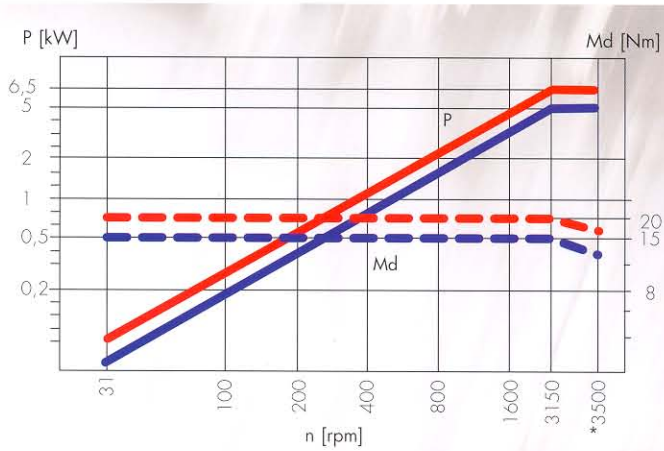

Powerful tool drive for drilling and milling operation.

\* For turret without Y axis 4,000 n[rpm]

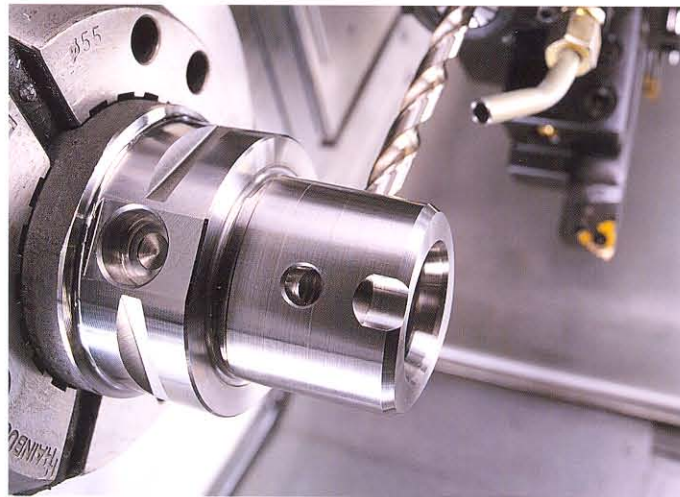

Machining with C-axis and driven tools on the main and counter spindle.

■ Complex drilling and milling operations through powerful tool drives in both turrets in conjunction with the standard C-axes on the main and counter spindle. For this, each turret station can be fitted with a driven tooling attachment.

Off-center machining with driven tools on both spindles is possible with the vertical Y-axis in the upper turret (3 1/8 inch traverse path  $\pm 1.6$  inch), without the use of complex or special tools.

Eccentric drilling and milling on both spindles with the Y-axis in the upper turret.



## The latest machine components

for high dynamics and workpiece quality.



■ Most technologically advanced components make the MF twin 42/65 into a production machine for small and medium lot sizes at an optimum in quality at an unparalleled price/performance ratio. Bar capacity is either 1 5/8 inch or 2 9/16 inch, chuck size standard is 8 inch optional it is 10 inch. A 45° inclined bed from high-grade casting forms a solid base for the two cross-slides and the two opposing spindles. This, combined with the undeniable workmanship of all GILDEMEISTER products, ensures the highest rate possible in metal-removing.

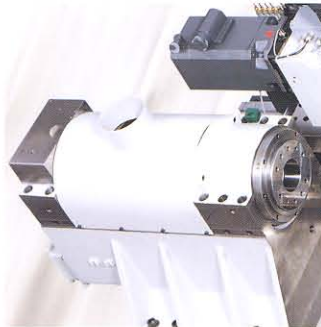

■ The main and counter spindles are designed as air-cooled integrated spindle motors. Since no transverse forces are exerted by the belt drive, the concentricity and surface finish are improved. In addition, high dynamics and short acceleration and braking times are achieved.

■ For economic machining, the main drive offers 19 hp (twin 42) or 28 hp (twin 65) the sub-spindle offers 16 hp for both modes. The preloaded linear roller guideways permit rapid traverse rates of up to 98.4 ft/min and avoid slip-stick effects. Through the combination of modern control and digital drive technology, increased interpolation precision achieves a major improvement in the workpiece quality and contour accuracy.





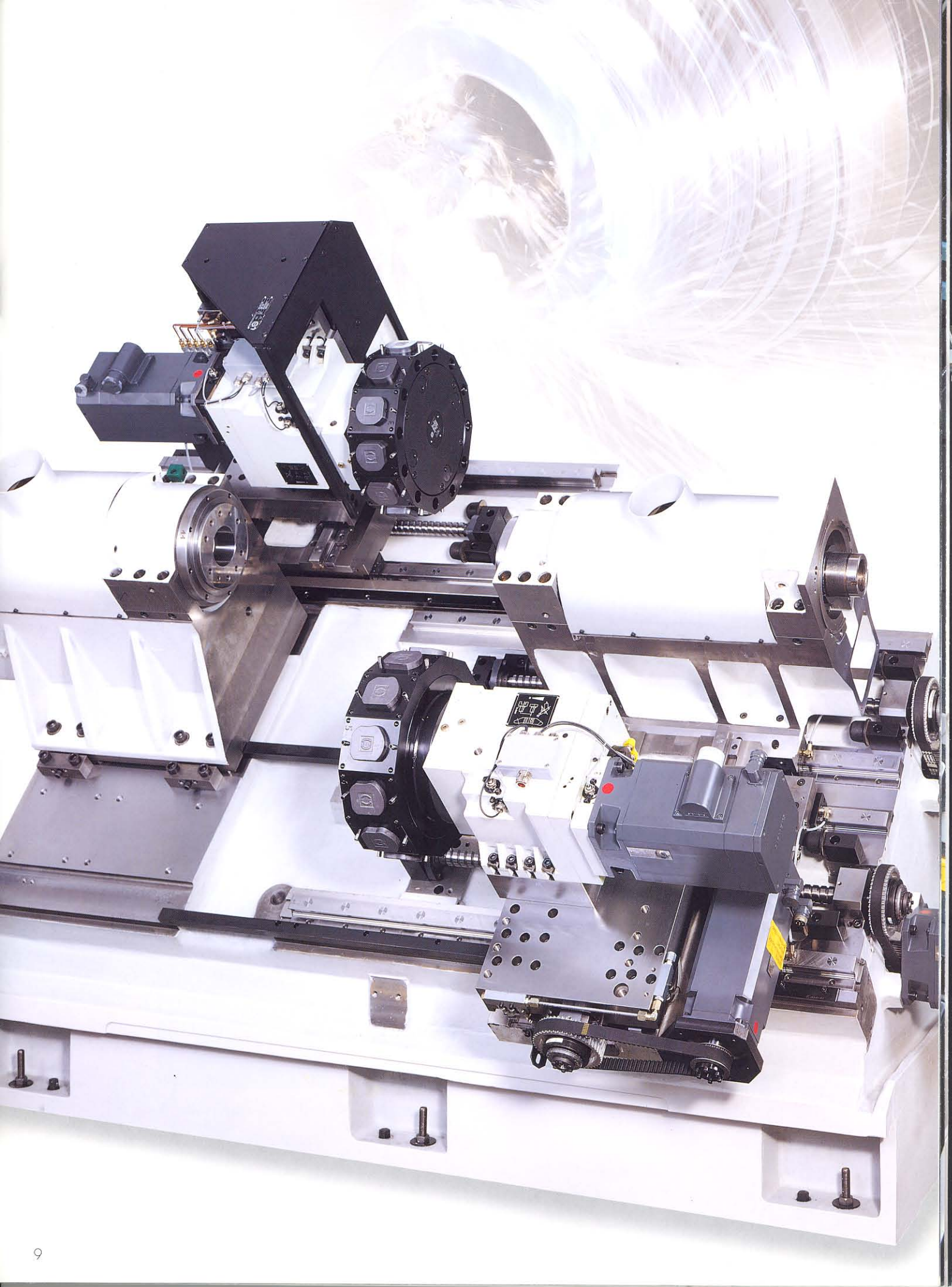

**F o r s p e c i a l d e m a n d s :**

**P l e a s e r e v i e w t h i s :**

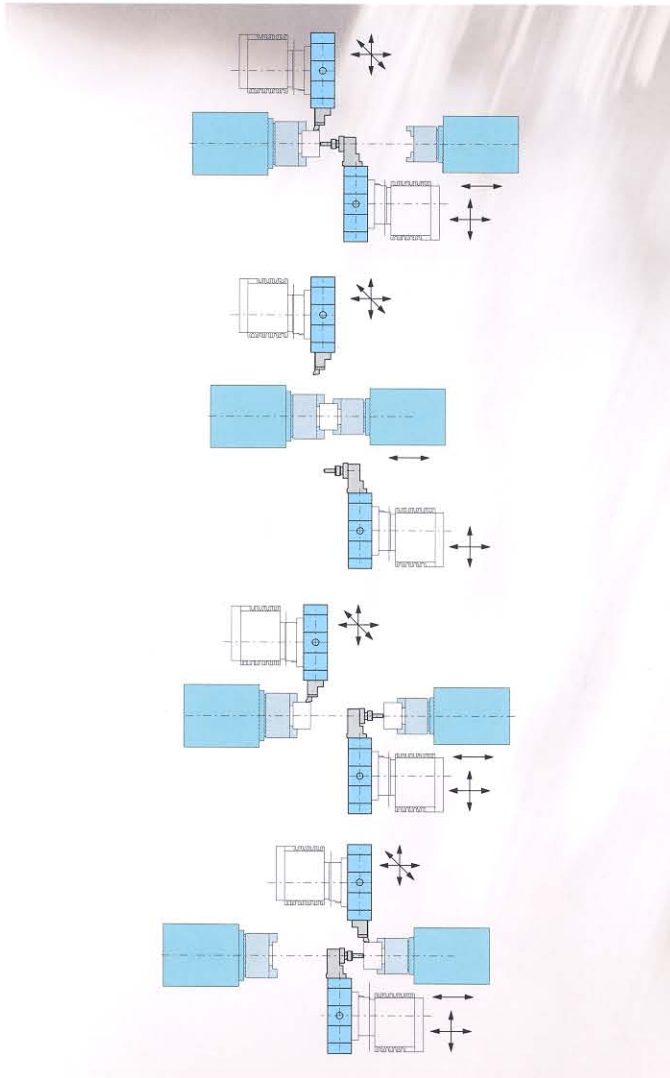

2 and 4 axis machining  
on the left hand spindle.

Transferring the semi-  
finished component using  
the travelling right hand  
headstock.

Independent machining  
on the right hand  
spindle.

2 and 4 axis machi-  
ning on the right hand  
spindle.

■ With the MF twin you obtain highest flexibility and economy. Through the use of both tool carriers it is possible to machine both 2 as well as 4 axes on each spindle.

In addition to turning operations, it is also possible to carry out machining with driven tools and C-axes. The use of the vertical Y-axis in the upper turret is also no problem at all on both spindles.

The flexible use of both tool carriers provides noticeable productive and cost advantages in practice. On workpieces with differing machining complexities for the first and second component side, can be compensated by using a 4-axes manufacturing process on the machining intensive side, hence reducing the cycle time. During 4-axis machining on one spindle, the next blank can be loaded at the other spindle and the finished part unloaded.

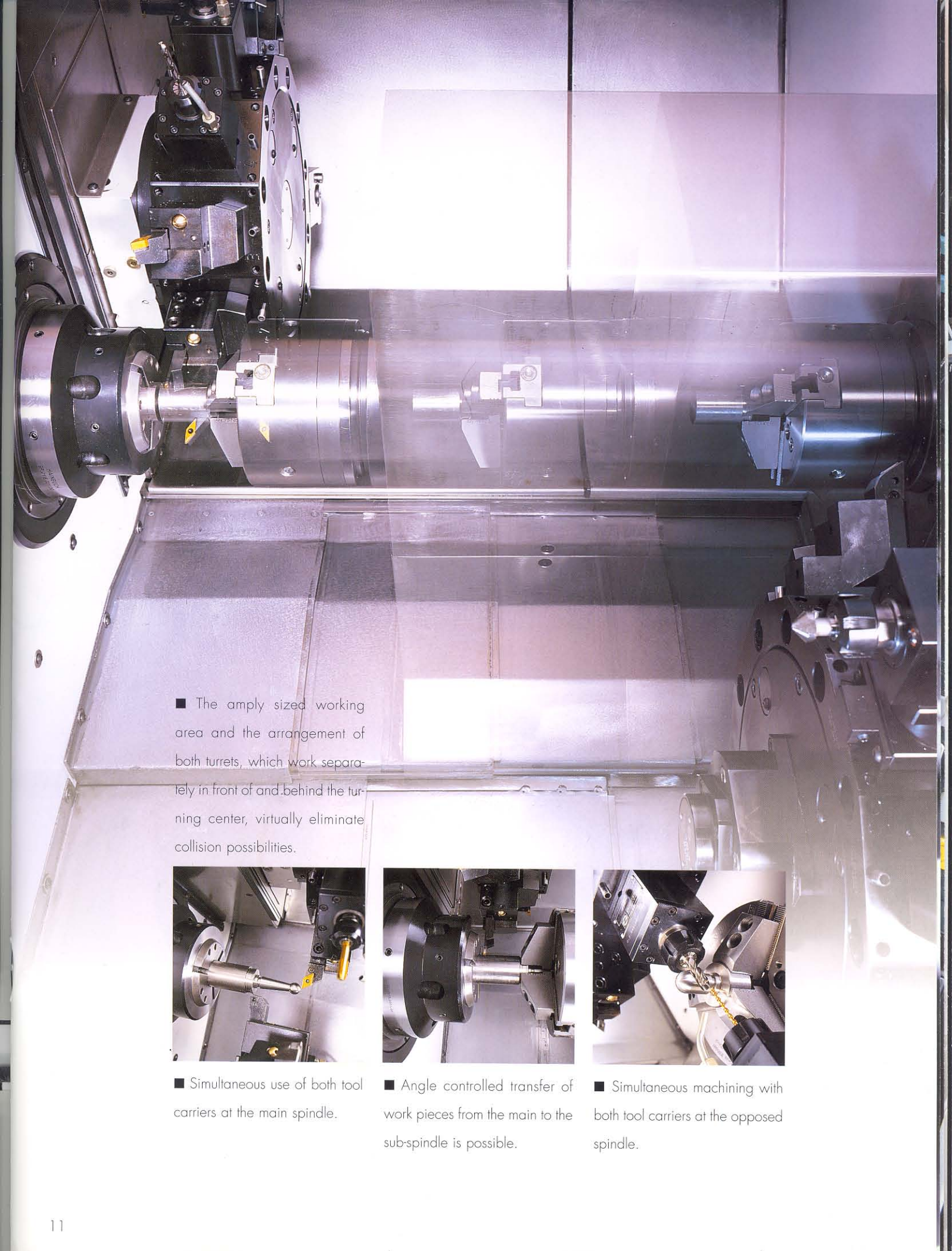

■ The amply sized working area and the arrangement of both turrets, which work separately in front of and behind the turning center, virtually eliminate collision possibilities.



■ Simultaneous use of both tool carriers at the main spindle.

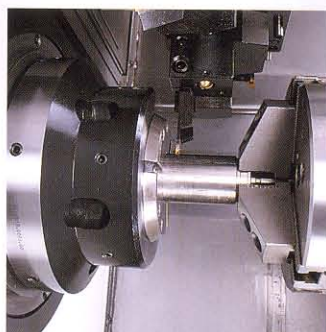

■ Angle controlled transfer of work pieces from the main to the sub-spindle is possible.

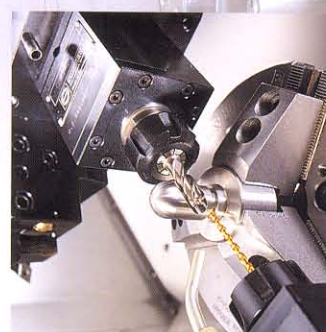

■ Simultaneous machining with both tool carriers at the opposed spindle.

Handling and

automation modules.

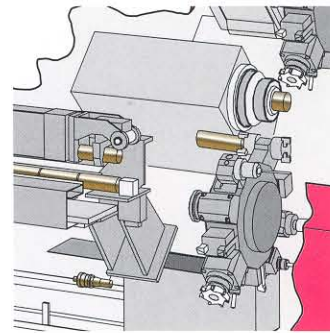

■ Different bar feed and bar loading magazines in conjunction with the appropriate parts catching devices, make the MF twin 42/65 into a high performance automatic production lathe for bar machining.

Two different systems are available for production of chucking parts in an automatic sequence: An integrated handling system consisting of a feed for horizontal or vertical workpiece transport, as well as a transport con-

veyor belt for workpiece removal. Loading of the blank on the main spindle as well as unloading of the finished part from the opposed spindle is performed by a hydraulic activated, programmable gripper in the lower turret. This solution is characterized by an exceptionally favorable price/performance ratio. Wide-ranging solutions consisting of a CNC loading gantry with various workpiece storage devices (continuous conveyor belts,

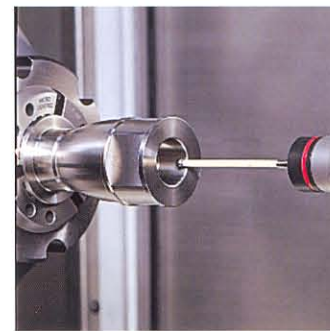

pallet indexing devices) are suitable for more complex applications, e.g. in conjunction with automatic measuring inside (in process) or outside (post process) the machine.



# E a s y   p r o g r a m m i n g

a n d   s i m p l e   o p e r a t i o n .



Trail-blazer in ergonomics and design: The 840 D control with flat colour screen makes it easy to use.

■ The Siemens 840 D control is part of the new control generation. This uses the familiar structures from the PC world and combines them with the special requirements of digital AC drive requirements. The result is an especially user friendly control, which displays, for example, all information in plain text, and this in various languages.

■ The Siemens 840 D is optimally matched to the MF twin and supports as a modular concept all modern programming functions through the integrated Pentium II PC Intel based computer with hard drive. Management of the programs, parameters, services and diagnosis takes place on the computer and within the MMC module. The data is loaded directly through job lists in the actual control.

■ The digital interface between the CNC control and the drives ensures trouble-free communication and improves the dynamic response and control behavior of the machine. Editing of the programs takes place via the integrated text editor, operation via the softkeys. The freely configurable window display on the standard flat color screen produces optimum clarity.



## Technical data

| Machine type                            |          | MF twin 42                           | MF twin 65         |
|---|----------|--------------------------------------|--------------------|
| <b>Bed</b>                              |          |                                      |                    |
| Design                                  |          | 45° inclined bed                     |                    |
| <b>Contour of the guides</b>            |          | rolled guides                        |                    |
| <b>Operating range</b>                  |          |                                      |                    |
| Swing diameter                          | inch     | 9.5                                  |                    |
| Turning diameter, normal                | inch     | 7.9                                  |                    |
| Spindle diameter                        | inch     | 31.5                                 |                    |
| <b>Spindle 1 (left)</b>                 |          |                                      |                    |
| Chuck diameter                          | inch     | 6                                    | 8                  |
| Bar diameter, max.                      | inch     | 1 5/8                                | 2 9/16             |
| Spindle nose diameter (flat flange)     | mm       | 140h5                                | 170h5              |
| Spindle bore diameter                   | inch     | 2.2                                  | 3.11               |
| Diameter in the front bearing           | inch     | 3.5                                  | 4.7                |
| <b>Spindle 2 (right)</b>                |          |                                      |                    |
| Chuck diameter                          | inch     | 6                                    | 8                  |
| Bar diameter, max.                      | inch     | 1 5/8                                | 1.7, 1 5/8, 2 9/16 |
| Spindle nose diameter (flat flange)     | mm       | 140h5                                | 140h5/170h5        |
| Spindle bore diameter                   | inch     | 2.2                                  | 2.2                |
| Diameter in the front bearing           | inch     | 3.5                                  | 3.5                |
| <b>Main drive (left)</b>                |          |                                      |                    |
| Input power max. [40/100% duty cycle]   | hp       | 25.5/18.8                            | 37.5/28.1          |
| Speed range                             | rpm      | 31-6300                              | 25-5000            |
| Buckle speed                            | rpm      | 1000                                 | 850                |
| Torque max. [40/100% duty cycle]        | ft./lbs. | 97.8/132.1                           | 233.6/175.2        |
| Drive type/range number                 |          | AC/1                                 |                    |
| Type                                    |          | Integrated spindle motor with C-axis |                    |
| <b>Main drive (right)</b>               |          |                                      |                    |
| Input power max. [40/100% duty cycle]   | hp       | 21.4/16.1                            |                    |
| Speed range                             | rpm      | 31-6300                              |                    |
| Buckle speed                            | rpm      | 1000                                 |                    |
| Torque max. [40/100% duty cycle]        | ft./lbs. | 84/113.2                             |                    |
| Drive type/range number                 |          | AC/1                                 |                    |
| Type                                    |          | Integrated spindle motor with C-axis |                    |
| <b>Slide 1 (top)</b>                    |          |                                      |                    |
| Cross travel X                          | inch     | 7.5                                  |                    |
| Longitudinal travel Z                   | inch     | 21.8                                 |                    |
| Vertical travel (option) Y              | inch     | ±1.6                                 |                    |
| Rapid traverse speed X/Y/Z              | inch/min | 787.2/295.2/1180.8                   |                    |
| Feed force X/Y/Z                        | daN      | 400/700/700                          |                    |
| <b>Slide 2 (bottom)</b>                 |          |                                      |                    |
| Face travel X                           | inch     | 7.5                                  |                    |
| Longitudinal travel Z                   | inch     | 21.8                                 |                    |
| Rapid traverse speed X/Z                | inch/min | 1787.2/1180.8                        |                    |
| Feed force X/Z                          | daN      | 400/700                              |                    |
| <b>Slide 3 (Spindle 2)</b>              |          |                                      |                    |
| Longitudinal travel                     | inch     | 6.3                                  |                    |
| Rapid traverse speed                    | inch/min | 1180.8                               |                    |
| Feed force                              | daN      | 700                                  |                    |
| <b>Tool carrier 1 and 2</b>             |          |                                      |                    |
| Number of tools                         |          | 2 x 12                               |                    |
| Shaft diameter according to DIN 69880   | inch     | 1.2                                  |                    |
| Number of driven tool stations          |          | 2 x 12                               |                    |
| Power, max. [40/100% duty cycle]        | hp       | 8.7/6.7                              |                    |
| Torque max. [40/100% duty cycle]        | ft./lbs. | 14.6/11                              |                    |
| Speed range                             | rpm      | 40 - 40000*                          |                    |
| <b>Dimensions and weights</b>           |          |                                      |                    |
| Overall length, with swarf conveyor     | inch     | 18.8                                 |                    |
| Overall depth, with control cabinet     | inch     | 87.4                                 |                    |
| Overall height, with control cabinet    | inch     | 76.8                                 |                    |
| Weight of machine, with control cabinet | lbs.     | approx. 16500                        |                    |

\* [40 - 3500] for tool carrier 1 with Y axis



# Operating space and tool carrier MF twin 42/65

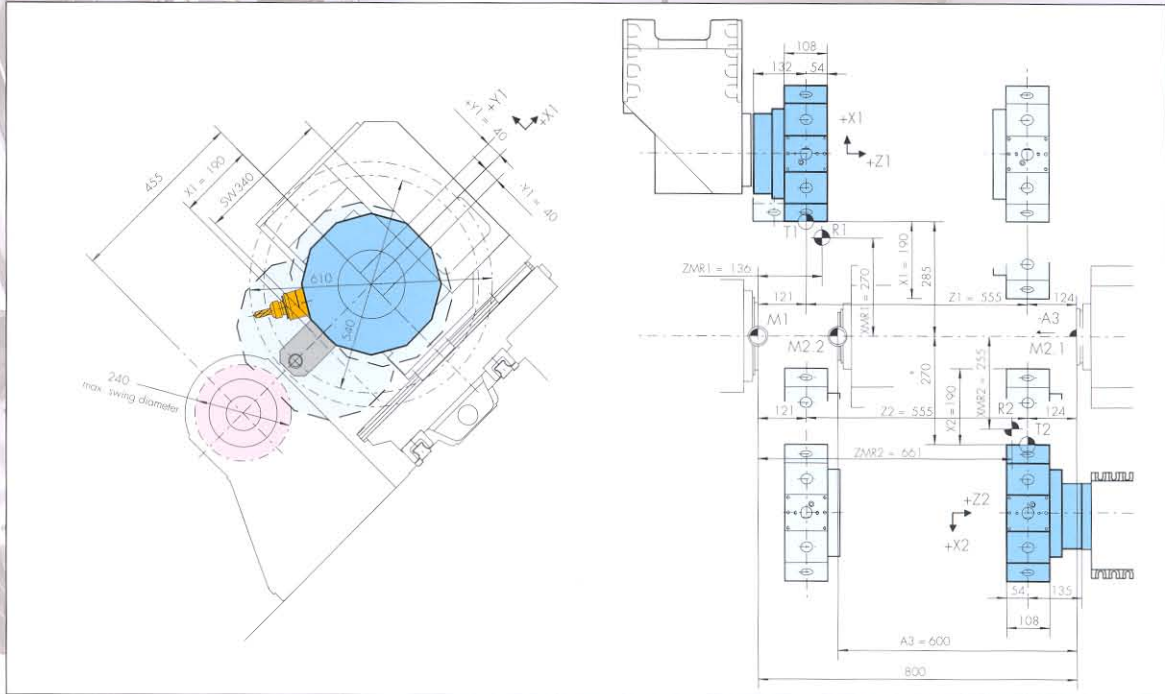

## Main drive MF twin 65

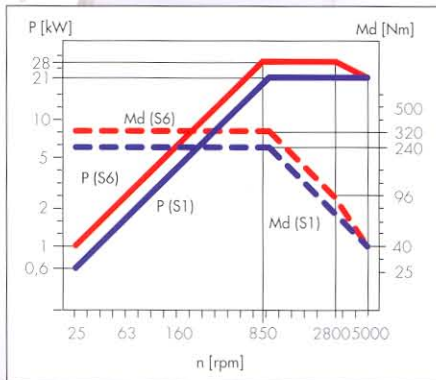

## Space requirement

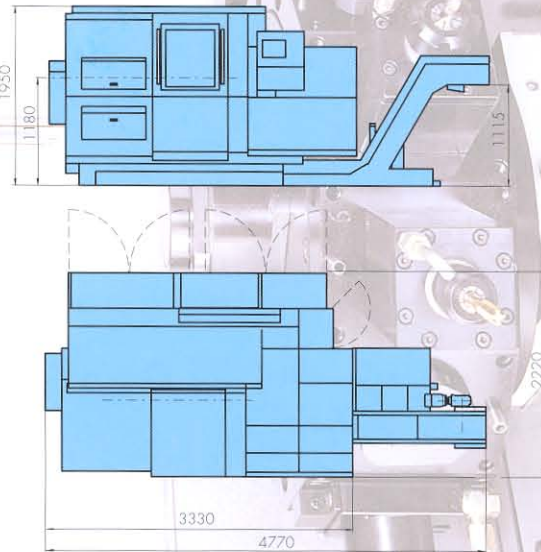

## Main drive MF twin 42

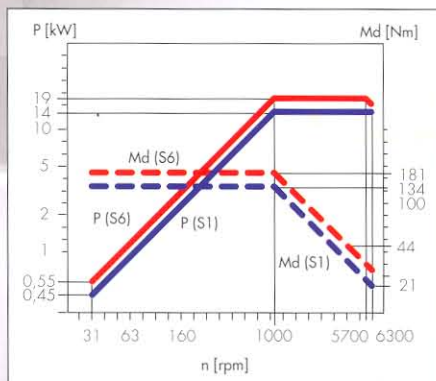

## Counterspindle MF twin 42/65

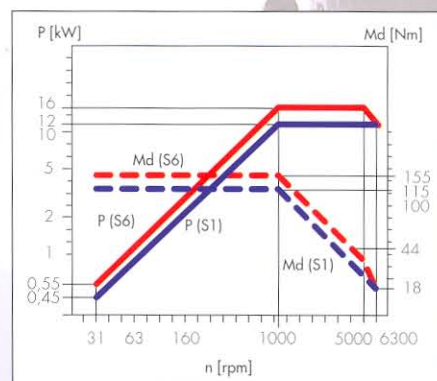

## Control Technical Data

### SIEMENS 840 C

| Function                             | Comments   |
|--------------------------------------|--|
| <b>Control type</b>                  | Path control for 2x2 axes, 1 main spindle with C axis, 1 counter-spindle with C axis, tool drive of turrets 1 and 2, Y axis (depends on machine)   |
| <b>Measuring systems</b>             | incremental measuring systems  |
| <b>Measurement system</b>            | metric, inch   |
| <b>Measurement input</b>             | Absolute dimension/incremental dimension   |
| <b>Input precision</b>               | 0.001 mm (0.0001 inch)   |
| <b>Interpolation type and scope</b>  | Linear $\pm$ 3935.999 inch/circular $\pm$ 3935.999 inch  |
| <b>Feed input</b>                    | direct in inch/rev. or inch/min  |
| <b>Feed superposition</b>            | 0-150%   |
| <b>Feed range</b>                    | 0.00004 inch/rev. to 393.6 inch/rev. (machine related)   |
| <b>Servo handwheel</b>               | for the fine adjustment of the slides, selectable ranges on the handwheel:<br>0.3936 / 0.003936 / 0.0000393 inch   |
| <b>Thread cutting</b>                | longitudinal, transverse and taper thread, from 0.0000393 - 19.7 inch/rev. pitch, single or multiple start with constant or variable pitch   |
| <b>Rapid traverse</b>                | transverse/longitudinal  |
| <b>Rapid traverse limitation</b>     | through parameter input  |
| <b>Spindle speed</b>                 | input in rev./min.   |
| <b>Spindle speed superimposition</b> | 50-150%  |
| <b>Spindle speed limitation</b>      | to be programmed and controlled via parameters   |
| <b>Spindle stop</b>                  | to be programmed   |
| <b>Coordinate system</b>             | absolute, incremental and Cartesian polar and cylinder coordinates   |
| <b>Constant cutting speed</b>        | input in inch/min.   |
| <b>Tool programming</b>              | position programming with tool data  |
| <b>Tool file</b>                     | 200 data records, for setting dimension and tool correction  |
| <b>Cutter radius compensation</b>    | available  |
| <b>Tool-life monitoring</b>          | toolLife monitoring with programmable strategy for replacement tools   |
| <b>Machining time</b>                | cycle time   |
| <b>Leadscrew error compensation</b>  | for all axes   |
| <b>Backlash compensation</b>         | available  |
| <b>Zero shift</b>                    | programmable   |
| <b>Part program memory</b>           | $\geq$ 200 MB on hard disk   |
| <b>Variable programming</b>          | with 500 global and 200 local variables, including trigonometric and arithmetic computing functions  |
| <b>Real time clock and date</b>      | secure against power failure   |
| <b>Diagnosis (automatic)</b>         | automatic self-diagnosis, display of current error conditions  |
| <b>Diagnosis following selection</b> | display of internal memory contents, input and output, drive diagnosis functions   |
| <b>Screen display</b>                | 10.4" TFT colour display   |
| <b>Screen structure</b>              | display of current data of all axes (position, speed) in the operating modes manual control and automatic, display of batch number, feed, tool number and tool correction of the relevant selected slide |
| <b>Clear text display</b>            | program text, block text, diagnosis text   |

**MF twin 65**  
**GILDEMEISTER**



Your Representative:

**DMG**  
America Inc.

**DECKEL MAHO GILDEMEISTER**

**DMG Chicago:** 1665 Penny Lane, Schaumburg, IL 60173, Tel.: (847) 781-0277, Fax: (847) 781-0388

**DMG Charlotte:** 13509 South Point Blvd., Charlotte, NC 28273 - 6759, Tel.: (704) 583-1193, Fax: (704) 583-1149

**DMG Houston:** 757 Kenrick, Suite 108, Houston TX 77060, Tel.: (281) 999-DMG1, Fax: (281) 999-1279

**DMG Los Angeles:** 17321 Pepper Tree St., Fountain Valley, CA 92708, Tel.: (714) 842-0663, Fax: (714) 842-0443

e-mail: [info@dmgamerica.com](mailto:info@dmgamerica.com), Internet: [www.gildemeister.com](http://www.gildemeister.com)