



**TRANSFER**

**Gosiger  
Import**



**BTB TRANSFER s.r.l.**

Via V. Veneto, 31 – 25073 BOVEZZO – (BS) Italy

Tel. +39-030-21.11.511

Fax +39-030-21.11.755 Sales Dept.

E-mail : sales@btb.it

**Offer:**

**Date:**

Further to your enquiry we have pleasure in forwarding the following quotation:

**1 TRANSFER MACHINE MOD.BB524 TRO 10S-10U ISO30 CN-EL with indexing table, HORIZONTAL axis, 10 working stations, 10 spindles UN-090 ELCN 110/30, 1 broach.**

**SERIAL NUMBER**

**MACHINING SPINDLE ARRANGEMENT**

LEFT SIDE = 4 MACHINING SPINDLES  
RIGHT SIDE = 6 MACHINING SPINDLES + 1 BROACH

**LAYOUTS FOR THE SPINDLES:** as per attached plan.

**N° 10 BORING SPINDLES Mod. UN-090 ELCN 110/30 DIN 2080** **CODE 30306X**

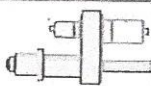

**FEED CONTROL**

Electric drive with **RECIRCULATING BALL SCREW** and Brushless servomotor.  
NC-controlled in all functions.

**UNIT DATA**

Useful stroke max.	110 mm
Quill diameter	90 mm
Bearing diameter	40 mm
Axial thrust	900 daN
Working speed Z axis	0 ÷ 22.5 m/min
Rapid Z axis	22.5 m/min
Spindle transmission	Cogged belt and multiratio pulley
Repeatability	±0.005 mm
Mounting on spindle nose	ISO30 TAPER DIN 2080



<b>FUNCTIONS</b>	Spindle motor	Single polarity electric motor with electronic <b>INVERTER</b> , for the continuous variation of the rotational speed of the spindle. Different types of transmissions available upon request.
	Motor power	3 KW
	Spindle rotation	Right
	<b>ISO RS 274 FREE PROGRAMMING OF Z AXIS</b> The standard program includes the following functions:	
	<ul style="list-style-type: none"> <li>• <b>TOOL MANAGEMENT</b></li> <li>• <b>TOOL OFFSETS</b> also in automatic cycle</li> <li>• <b>INTEGRATED PRODUCTION MANAGEMENT</b></li> <li>• <b>DIAGNOSTIC PROGRAMMING</b> with historical alarm management</li> <li>• <b>HOUR PRODUCTION DAILY REPORT</b></li> <li>• <b>SPECIAL CYCLES:</b> anticollision, recessing, etc.</li> </ul>	

<b>INDEXING TABLE HORIZONTAL AXIS Mod. TRO-3C Ø650/700/800</b>		<b>CODE 31005</b>
	<b>ROTATION</b>	Controlled by a BRUSHLESS motor with constant acceleration and deceleration without requiring mechanical adjustment.
	<b>CYCLE TIME</b>	0.4 sec including table unlocking/locking movement.
	<b>LOCK/UNLOCK</b>	The indexing table is hydraulically locked to the machine frame with 3 Hirth - Type Face Gear. Locking/unlocking hydraulic device equipped with electric sensors for both positions.
	<b>PRECISION</b>	Positioning precision: ±3" (tighter tolerances are available upon request at an additional cost).
	<b>ADDITIONAL FEATURES</b>	The internal positive pressure prevents chips and coolant from entering the table mechanism.

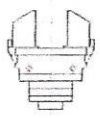
<b>N°10 SELF-CENTERING CHUCKS Mod. M1-11</b>		<b>CODE 32001</b>									
	<b>DESCRIPTION</b>	Hydraulic control with adjustment of clamping pressure. <b>Jaw movement by means of levers.</b> The chucks are manufactured from casehardened steel, hardened and precision ground. The chucks are internally pressurised and lubricated with a fine oil mist spray to prevent chips and coolant from entering the chuck mechanism.									
	<b>TECHNICAL FEATURES</b>	<table border="0"> <tr> <td>Useful stroke max.</td> <td>11 mm (5.5 each slide)</td> </tr> <tr> <td>Clamping force</td> <td>260 daN at 40 bar</td> </tr> <tr> <td>Clamping pressure</td> <td>Adjustable from 5 to 50 bar</td> </tr> <tr> <td>Stroke adjustment</td> <td>Up to 0 mm by central adjusting screw</td> </tr> <tr> <td>Jaw carrier</td> <td>Included</td> </tr> </table>	Useful stroke max.	11 mm (5.5 each slide)	Clamping force	260 daN at 40 bar	Clamping pressure	Adjustable from 5 to 50 bar	Stroke adjustment	Up to 0 mm by central adjusting screw	Jaw carrier
Useful stroke max.	11 mm (5.5 each slide)										
Clamping force	260 daN at 40 bar										
Clamping pressure	Adjustable from 5 to 50 bar										
Stroke adjustment	Up to 0 mm by central adjusting screw										
Jaw carrier	Included										

<b>MACHINE BASE Mod. TRO 10S-16U</b>	<b>CODE 34016A</b>
--------------------------------------	--------------------





<b>DESCRIPTION</b>	Fabricated from electrowelded steel with substantial cross ribbing designed to guarantee maximum stiffness and the absence of vibrations during the machining operations. Normalized and sand-blasted before machining, hand-scraped and inspected with precision gauges on every geometric plane after the mounting bores have been finished.
<b>NO. OF UNITS</b>	The base is machined and hand scraped to allow up to 20 working spindle units to be mounted. The unused stations are nevertheless completely machined and hand scraped to allow for future additions.
<b>TECHNICAL FEATURES</b>	Loading on station 10 and unloading on station 9.

**WATER SOLUBLE COOLANT SYSTEM** for tools, equipped with taps (located on the outside of the working area) for regulation of the rate of flow for each spindle.  
**HYDRAULIC POWER UNIT** with variable volume pump. All hydraulic items are ISO standard and therefore interchangeable with all major name brand hydraulic items (i.e. solenoid valves).

**ELECTRICAL CONTROL**

**GE FANUC 9070** based CNC. Integrated with **DELTA TAU** Pmac axis cards, that are capable of coordinating and controlling 192 axes simultaneously in any configuration resulting the most efficient and fastest, (max. servo update time 440 micro seconds), dedicated controller for transfer machines on today's market.

Universal digital drives **SIEMENS 611**, combined with **MOOG** digital motors, (in alternative Siemens) offer the ideal solution for compactness, reliability, and flexibility necessary to guarantee the best customized configuration for delivering controlled power to all motors.

**Telemecanique** variable speed controllers, (alternatives available on request), are sparingly used to optimise all spindle speeds.

The control cabinet, housing all the components (Telemecanique or Siemens for the contactors), is climatically controlled so as to guarantee ideal working temperature and humidity even in the worst environmental conditions.

*No one is a specialist in all fields and only after years of experience the above combination outclasses standard compromises using only the best of the worlds leading manufactures.*

A dedicated HMI allows the operator to be guided step by step in programming and controlling the machine in all its functions.

All job programs are simply written in ISO RS 247 (Standard G Code).

Tool lengths, part programs, programs, timers and counters can be all saved and recalled easily for fast change over times.

Alarms are clearly displayed on the screen, dedicated custom photos with instructions, help the operator in diagnosing and resolving any given situation which might occur.

The interface runs on a normal windows based PC with a high resolution LCD 15" monitor, preinstalled with all the essential programs necessary to reconfigure, tune drives, and perform advanced programming and debug for the plc and cnc.

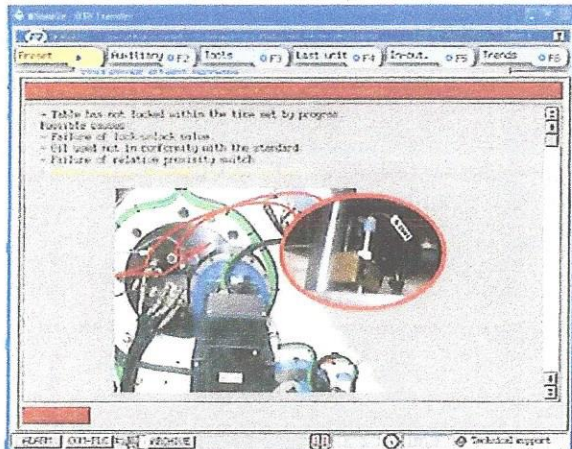

The PC normally located in the control cabinet, is supplied with a modem and Ethernet connection so as to facilitate the machine integration on your local network and combine our online **Teleservice** feature to enable our service personnel to operate in real time by remoting your PC directly to our facility thus controlling program errors and updating your software without costly service calls.

### **SAFETY GUARDS**

**LIGHT CURTAINS** are provided for all manually loaded machines.

All dangerous areas are protected by means of doors which are electromechanically interlocked assuring maximum safety for the operator. Furthermore, all other moving parts that are not located within the safety doors, are only accessible by removing bolts or fasteners, and therefore always ensure maximum protection for the operator.

**AUTOMATIC CENTRAL LUBRICATING AND PRESSURISING UNIT.** Maintains a positive air pressure differential to prevent chips or coolant from entering the critical moving parts of the indexing table and chucks.

**ACCORDING TO USA NORMS**



## ADDITIONAL EQUIPMENT

.001\_\_\_\_\_ Chip and coolant processing system consisting of a chain conveyor, specially designed for **medium steel chips**, safety overload clutch for jam-up protection and reverse command, with pump assembly suitable for the following systems:

- Labyrinth collector with decantation tank.
- Filtering basket with 1000  $\mu$  steel filter net.
- Magnetic separator with magnetic plates (discs) for separation of the ferrous particles in suspension.
- Pre-filtering assembly inclusive of a motorized rotating filter and a self-washing system, with 300 to 1000  $\mu$  filtering capacity.
- Prearrangement for connection of the coolant refrigeration and temperature control system (not included in the supply).

Qty. 1

---

.004\_\_\_\_\_ Coolant refrigeration system with automatic temperature control system to maintain the coolant coming from the tank at approx. 15°C (59°F) above ambient temperature.

Qty. 1

---

.306\_\_\_\_\_ Quick change toolholder system with hydraulic control to release the toolholder. Controlled by a convenient portable electric keypad. Locking of the toolholder is achieved through Belleville spring washers to prevent the toolholder from releasing in case of a power interruption. To be used with a safety pin (not supplied).

Qty. 5

---

- .119 \_\_\_ Quick change toolholder system with hydraulic control to release the toolholder. Controlled by a convenient portable electric keypad. Locking of the toolholder is achieved through Belleville spring washers to prevent the toolholder from releasing in case of a power interruption. To be used with a safety bar pin (not supplied). Equipped with **pressurized through the spindle coolant** by means of an internal line at the back of the distributor.  
Qty. 2
- 
- .111 \_\_\_ **KOMET 100-CNEL** recessing head with ball screw control system, N.C. programmable and controlled, stroke 15mm, **2 axes interpolation, 3 axes interpolation for mounting on a standard CNC threading-boring unit**. Rpm. max: 1500 (not compatible with code .306)  
Qty. 3
- 
- .401 \_\_\_ Hydraulic pusher with adjustable stroke from 10-60 mm, with anti-rotation device, for mounting on a prearranged machine base.  
Qty. 1
- 
- .402 \_\_\_ Hydraulic broach, adjustable in front and back position with self-centering connection, stroke 100mm, max. power 2000 Kg.  
Qty. 1
- 
- .601 \_\_\_ Pneumatic loading system controlled by a Siemens PLC to load workpiece to the machine, complete with manipulator arm to enable front or lateral loading and with a circular vibrator prearranged to select a part at your choice.  
Complete with sound insulating cap for the loader with hinged cover for loading the blank parts and to allow easy access for inspection and loading side with 1000mm (40") movement to facilitate access to the transfer machine.  
Qty. 1
-







- .604 Roller-shutter elevator to feed circular vibrator complete of hopper - capacity 150 lt.  
Qty. 1
- 
- .801 Complete documentation in English language including instruction book with the spare parts lists, tool drawings, maintenance drawings, electrical, hydraulic and pneumatic schematic drawings, programming, operation and maintenance instructions.  
Qty. 1
- 
- .806 Installation and training of your personnel for general operations, maintenance and programming, carried out at customer's facility by two BTB's engineers for a period of two weeks. Their travel and living expenses (board and lodging) will be our responsibility.  
Qty. 1
- 
- .941 Device for **Remote Assistance** inclusive of program and connection to our company via modem. It allows the on-line connection to the transfer machine, the modification of the program directly by BTB. It requires only a direct phone line provided by the client. After the expiry of the guarantee period, it will be possible to draw up a ~~contract to make use of this~~

A handwritten signature or mark in the right margin of the page.



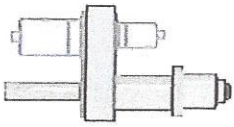

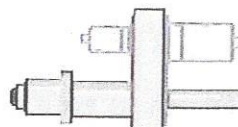
TYPE: <b>BB TRO 10S/10U ISO30 CN-EL BAR</b> OFFER No: <b>55/2005</b> CUSTOMER:	
FILE Name : <b>1.</b>	<b>UNITS DISTRIBUTION</b>



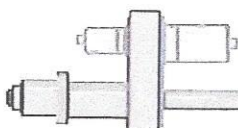

**STATION 1**

1,1- BORING SPINDLE UN-090 ELCN 110/30				1,3- BORING SPINDLE UN-090 ELCN 110/30
				

**STATION 2**

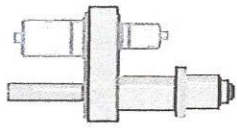
2,1- MECHANICAL PREARRANGEMENT				2,3- BORING SPINDLE UN-090 ELCN 110/30
				KOMET 100 CN-EL

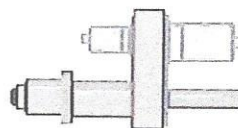
**STATION 3**

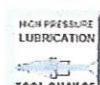
3,1- BORING SPINDLE UN-090 ELCN 110/30				3,3- BORING SPINDLE UN-090 ELCN 110/30
				



**STATION 4**

4,1- BORING SPINDLE  
UN-090 ELCN 110/30

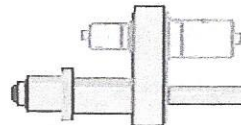
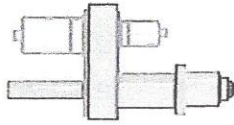

4,3- BORING SPINDLE  
UN-090 ELCN 110/30



**STATION 5**

5,1- BORING SPINDLE  
UN-090 ELCN 110/30

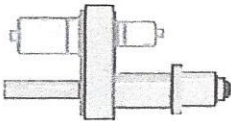

5,3- MECHANICAL  
PREARRANGEMENT



KOMET 100 CN-EL

**STATION 6**

6,1- HYDRAULIC PUSHER

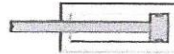
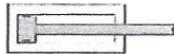

6,3- HYDRAULIC BROACH

**STATION 7**

6,1- MECHANICAL PREARRANGEMENT

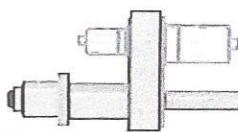

7,3- BORING SPINDLE  
UN-090 ELCN 110/30



**STATION 8**

8,1- MECHANICAL PREARRANGEMENT

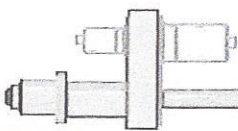



8,3- BORING SPINDLE  
UN-090 ELCN 110/30

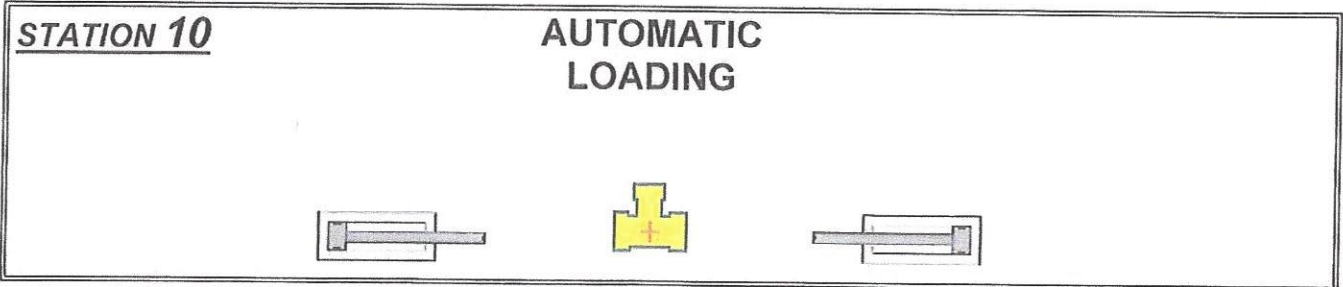
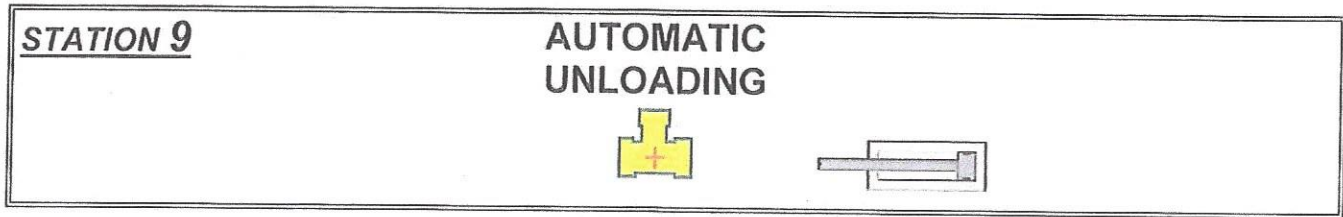

KOMET 100 CN-EL

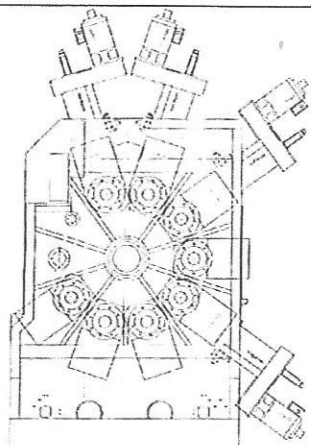
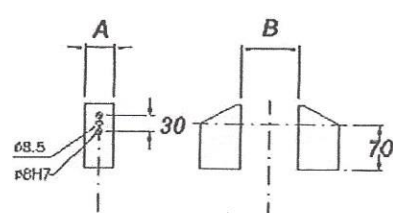

<b>TECHNICAL DATA</b>		
<b>FRAME SHAPE</b>	<b>JAW CARRIER</b>	<b>UNIT DISTANCE FROM CENTRE</b>
	<p>A= 35mm B= 90mm</p>  <p>CHIUSURA= 90mm</p>	 <p>A=200 B=200</p>
<b>TABLE DIAMETER : 800</b>	<b>CHUCK TYPE : M1</b> <b>STROKE 11mm (5.5+5.5)</b>	<b>note :</b>